

# OWNER'S MANUAL



## AKORN<sup>®</sup> AUTO-KAMADO<sup>™</sup>

Model #6480 / E6480



**Keep your receipt with  
this manual for Warranty.**

**CUSTOMER SERVICE  
AutoKamado@CharGriller.com**

**PATENTED & PATENT PENDING**

Contents of this manual are Trademarked and Copyrighted by Char-Griller<sup>®</sup> | A&J Manufacturing  
Using the information contained in this manual without consent of Char-Griller<sup>®</sup> and/or A&J Manufacturing is strictly prohibited.



# TABLE OF CONTENTS

Safety Warnings & Warranty.....	A-1
Assembly Instructions .....	B-1
Product Usage .....	C-1
Recipes .....	D-1
Accessories .....	E-1



## ATTENTION!

Please Review ALL of the Lighting Instructions Prior to Operating Grill



- **DO NOT** use a charcoal chimney to ignite charcoal. Over-activation of charcoal will prevent controller from being able to control temperature.
- **BE PATIENT.** Time to reach desired temperature will vary by fuel type, number of fire starters and placement, as well as weather conditions. See Lighting Instructions on pages C-2 – C-5.
- Use **ONE** fire starter for smoking (200-250°F).
- **TWO** fire starters can be used to achieve higher temperatures (350-700°F).
- The appropriate fuel amount must be added to reach desired temperature. See Lighting Instructions on pages C-2 – C-5.
- When smoking (200-250°F), if the grill exceeds the set temperature by +50°F it may be challenging to reach desired temperature.
- It is **NOT** possible to go from Grilling or Searing (350-700°F) to Smoking temperatures (200-250°F). Grill must be shut down, charcoal extinguished, and restarted 1-2 hours later.
- **DO NOT** set temperature to higher than desired temperature in an attempt to reach desired temperature faster. This will result in over activating the charcoal and inability to maintain the desired temperature.
- **DO NOT** use the Heat Deflector at temperatures higher than 450°F.

# IMPORTANT SAFETY WARNINGS

## READ ALL SAFETY WARNINGS AND INSTRUCTIONS CAREFULLY BEFORE ASSEMBLING AND OPERATING YOUR GRILL

Read the following instructions carefully and be sure your grill is properly assembled, installed, and maintained. Failure to follow these instructions may result in serious bodily injury and/or property damage. If you have any questions concerning assembly or operation, email [AutoKamado@CharGriller.com](mailto:AutoKamado@CharGriller.com).

- Grill is for use outdoors and in well-ventilated areas, only.
- Use caution when assembling and operating your grill to avoid scrapes or cuts from sharp edges
- Do NOT use lighter fluid, gasoline, kerosene, alcohol or other accelerant for lighting charcoal due to flammability, risk of bodily injury and potential to leave a distasteful flavor in your food.
- Do NOT leave a lit grill unattended. Keep children and pets away from grill at all times.
- Do NOT use grill in high winds.
- Use caution when moving grill to prevent strains.
- The use of alcohol, prescription or non-prescription drugs may impair the operator's ability to properly assemble or safely operate the grill.
- Use grill at least 3 ft. from any wall or surface. Maintain 12 ft. clearance to objects that can catch fire or sources of ignition such as pilot lights on water heaters, live electrical appliances, etc.
- When adding charcoal and/or wood, use extreme caution.
- Never move grill when it is in use or when it contains hot coals or ashes.
- Do NOT use grill for indoor cooking or heating. TOXIC fumes can accumulate and cause asphyxiation.
- Do NOT use in or on boats or recreational vehicles.
- Do NOT place grill near flammable liquids, gases, or where flammable vapors may be present.
- When cooking with oil/grease, do not allow the oil/grease to exceed 350°F (177°C). Do not store or use extra cooking oil in the vicinity of this or any other grill.
- When cooking with oil or grease, have a type BC or ABC fire extinguisher readily available.



**WARNING:** FUELS USED IN WOOD OR CHARCOAL BURNING APPLIANCES, AND THE PRODUCTS OF COMBUSTION OF SUCH FUELS, CAN EXPOSE YOU TO CHEMICALS INCLUDING CARBON BLACK, WHICH IS KNOWN TO THE STATE OF CALIFORNIA TO CAUSE CANCER, AND CARBON MONOXIDE, WHICH IS KNOWN TO THE STATE OF CALIFORNIA TO CAUSE BIRTH DEFECTS OR OTHER REPRODUCTIVE HARM. *For more information go to:* [www.P65Warnings.ca.gov](http://www.P65Warnings.ca.gov).

**ADVERTENCIA:** LOS COMBUSTIBLES USADOS EN EQUIPOS PARA QUEMAR MADERA O CARBÓN, ASÍ COMO LOS PRODUCTOS DE TAL COMBUSTIÓN, PUEDEN EXPONERTE A SUSTANCIAS QUÍMICAS, ENTRE ELLAS EL NEGRO DE HUMO Y EL MONÓXIDO DE CARBONO, QUE EL ESTADO DE CALIFORNIA RECONOCE COMO CAUSA, RESPECTIVAMENTE, DE CÁNCER Y DE MALFORMACIONES CONGÉNITAS Y OTROS DAÑOS AL SISTEMA REPRODUCTOR. *Para más información, visite [www.P65Warnings.ca.gov](http://www.P65Warnings.ca.gov)*



# **IMPORTANT SAFETY WARNINGS**

## **(Continued)**

- In the event of an oil or grease fire do not attempt to extinguish with water. Immediately call the fire department. A type BC or ABC fire extinguisher may, in some circumstances, contain the fire.
- Use caution since flames can flare-up when fresh air suddenly comes in contact with fire.
- Do NOT lean over an open grill and be mindful of hands/fingers near the edge of the cooking area.
- When opening the lid, keep hands, face, and body safe from hot steam and flame flare-ups.
- **WARNING:** To avoid injuries, gloves or other protective articles should be used when operating the grill.
- Do NOT exceed a temperature of 700°F.
- Do NOT allow charcoal and/or wood to rest on the walls of grill. Doing so will greatly reduce the life of the grill.
- Always wear grill gloves to protect hands from burns. Avoid touching hot surfaces.
- **CAUTION:** Exposed metal dampers on air vents and/or metal handles are hot during usage. Again, always wear grill gloves when adjusting air flow to protect hands from burns.
- Do NOT alter this grill in any manner.
- When opening lid, make sure it is pushed all the way back so it rests against the lid support brackets. Use extreme caution as lid could fall back to a closed position and cause bodily injury.
- Close lid and all dampers to help suffocate flame.
- Always hold an open lid from the handle to prevent it from closing unexpectedly.
- Never leave coals and ashes unattended. Before grill can be left unattended, coals and ashes must be removed. Use caution to protect yourself and property.
- Carefully place remaining coals and ashes in a noncombustible metal container and saturate completely with water. Allow coals and water to remain in a metal container for 24 hours prior to disposing.
- The grill lid and ash pan are HOT while in use and will remain HOT for a period of time afterwards and during cooling process. Use CAUTION. Wear protective gloves/mitts.
- Grill has an open flame. Keep hands, hair, and face away from flame. Do NOT lean over grill when lighting. Loose hair and clothing may catch fire.
- Do NOT cover cooking grates with metal foil. This will trap heat and may cause damage to the grill.
- Never overfill the fire bowl. This can cause serious injury as well as damage to the grill.
- When using electrical appliances, basic safety precautions should always be followed including the following: 1) Do not plug in the appliance until fully assembled and ready for use. 2) Use only approved grounded electrical outlet. 3) Do not use during an electrical storm. 4) Do not expose appliance to rain or water at any time.

- To protect against electrical shock do not immerse cord, plug or control panel in water or other liquid.
- Do NOT operate any appliance with a damaged cord or plug, or after appliance malfunctions or has been damaged in any manner. Contact Char-Griller® Customer Service for assistance at [AutoKamado@CharGriller.com](mailto:AutoKamado@CharGriller.com).
- Extension cords may be used if care is exercised in their use. If an extension cord is used:
  - 1) The marked electrical rating of the extension cord should be at least as great as the electrical rating of the appliance.
  - 2) The cord should be arranged so that it will not drape over the counter top or tabletop where it can be pulled by children or tripped over unintentionally.
- The extension cord must be a grounding-type 3-wire cord.
- Outdoor extension cords must be used with outdoor use products and are marked with suffix “W” and with the statement “Suitable for Use with Outdoor Appliances.”
- CAUTION - To reduce the risk of electric shock, keep extension cord connection dry and off the ground.
- Do NOT let cord hang on or touch hot surfaces.
- Do NOT place cord on or near a gas or electric burner or in a heated oven.
- To disconnect, turn controller “OFF” then remove plug from outlet.
- Unplug from outlet when not in use and before cleaning. Allow appliance to cool completely before adding/removing internal components.
- Do NOT clean this product with a water sprayer or the like.
- If it is necessary to refill charcoal during use follow the specific reload instructions for this grill and always wear protective gloves.
- Never operate the grill with the temperature probe removed. This can cause the grill to overheat and cause serious personal injury and/or damage to the grill.
- To protect against bacteria that could cause illness, keep all meats refrigerated and thaw in refrigerator or microwave. Keep raw meats separate from other foods, and wash everything that comes in contact with raw meat.
- Cook meat thoroughly, and refrigerate leftovers immediately.
- Use a calibrated food thermometer and the USDA guidelines to ensure that meat, poultry, seafood, and other cooked foods reach a safe minimum internal temperature.
- Always have type BC or ABC fire extinguisher near at all times. Maintain and check your fire extinguisher regularly.



**\*\*\* STOP! CONTACT  FIRST! \*\*\***

**Do NOT Return Product to Store.**

This grill has been made according to the highest of quality standards. If you have any questions not addressed in this manual or if you need parts please email our Customer Service Department at: [AutoKamado@CharGriller.com](mailto:AutoKamado@CharGriller.com) and have your serial number handy.

**REGISTER YOUR GRILL:**

To take full advantage of the Char-Griller® warranty be sure to register your grill by visiting [www.CharGriller.com/Register](http://www.CharGriller.com/Register) or emailing Customer Service at [AutoKamado@CharGriller.com](mailto:AutoKamado@CharGriller.com).

Registration provides important protections:

1. Register your grill today to activate your warranty and get exclusive access to product developments, updates, and recipes.
2. This allows us to help you get warranted parts to your quickly and provide enhanced customer service.

*NOTE:* You will need your model number, serial number, and a copy of the original sales receipt when registering.



**Document Your Serial Number HERE:**

(Serial number is located on the back of the grill body or on the leg.)

\_\_\_\_\_  
**(SERIAL #)**

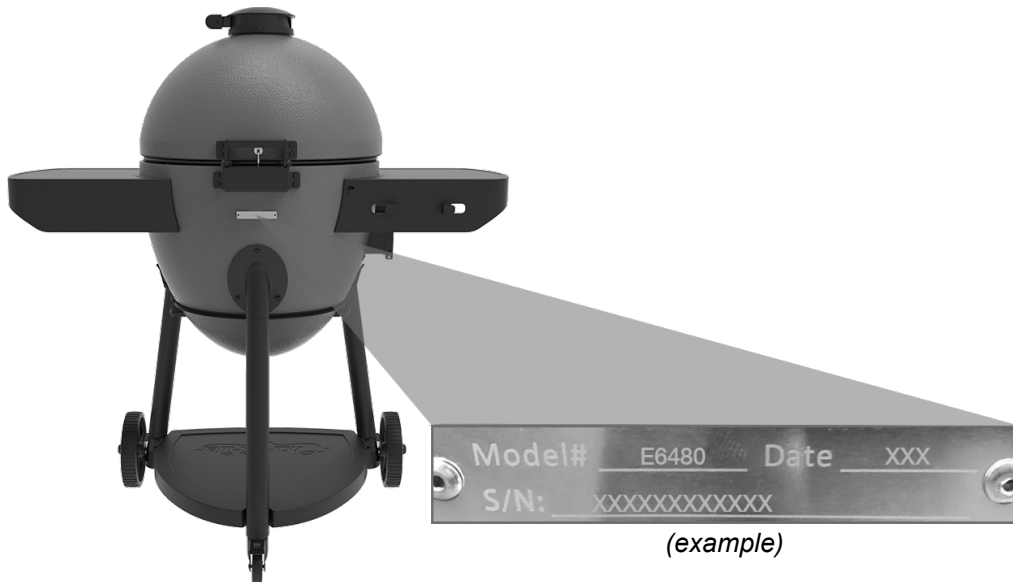

# WARRANTY INFORMATION

**A COPY OF THE DATED PROOF OF PURCHASE (RECEIPT) IS REQUIRED WHEN REGISTERING OR SUBMITTING A WARRANTY\* CLAIM. PLEASE RETAIN A COPY OF THE RECEIPT FOR YOUR RECORDS.**

Char-Griller® will replace any defective part of its grillers/smokers, under warranty, as outlined below.

**PLEASE READ THIS INFORMATION IN DETAIL AND IF YOU HAVE ANY QUESTIONS CONTACT CUSTOMER SERVICE AT AUTOKAMADO@CHARGRILLER.COM.**

<b>Gravity</b>	
All Defective Parts	1 year from date of purchase
<b>Charcoal / Pellet / Kamado Grills</b>	
Grill - Hood AND Bottom (excludes removable Ash Pan)	5 years from date of purchase for rust through / burn through
Ash Pan AND Defective Parts	1 year from date of purchase
<b>Gas Grills</b>	
Grill Hood (TOP half) AND Main Burner Tubes (excludes Side Burner)	5 years from date of purchase for rust through / burn through
Grill Body (BOTTOM half) AND Side Burner AND Defective Parts	1 year from date of purchase
<b>Dual Fuel Grills (Gas &amp; Charcoal)</b>	
Charcoal Grill - Hood AND Bottom AND Gas Grill Hood (TOP half) AND Main Burner Tubes (excludes Ash Pan and Side Burner)	5 years from date of purchase for rust through / burn through
Ash Pan AND Defective Parts AND Gas Grill Body (BOTTOM half) AND Side Burner	1 year from date of purchase
<b>Parts, Accessories, and Grill Covers</b>	1 year from date of purchase (seam tears only for covers)

## SURFACE RUST IS NOT CONSIDERED A MANUFACTURING OR MATERIALS DEFECT

Char-Griller® grills are made of steel and if exposed to the elements rust will occur naturally. Please refer to the section entitled, "Usage" to review how to care for your grill properly.

Surface issues such as scratches, dents, corrosion or discoloring by heat, abrasive and chemical clearers, surface rust or the discoloration of steel surfaces are NOT covered under these warranties.

Warranties are for the replacement of defective parts only. Char-Griller® is not responsible for damage resulting from accident, alteration, misuse, abuse, hostile environments, improper installation, and installation not in accordance with local codes of service of unit.

### Excluded Under ALL Warranties

Paint; Surface Rust; Heat Damage; Incorrect Parts ordered by customer, including shipping; Worn Parts; Missing or damaged parts not reported within two (2) months of purchase date; Defective parts not reported within one (1) year of purchase date; Fading grill cover.

\*NOTE: For warranty claims, photos and prepaid return of the item in question may be required. Misuse, abuse or commercial use nullifies all warranties.

# ASSEMBLY INSTRUCTIONS

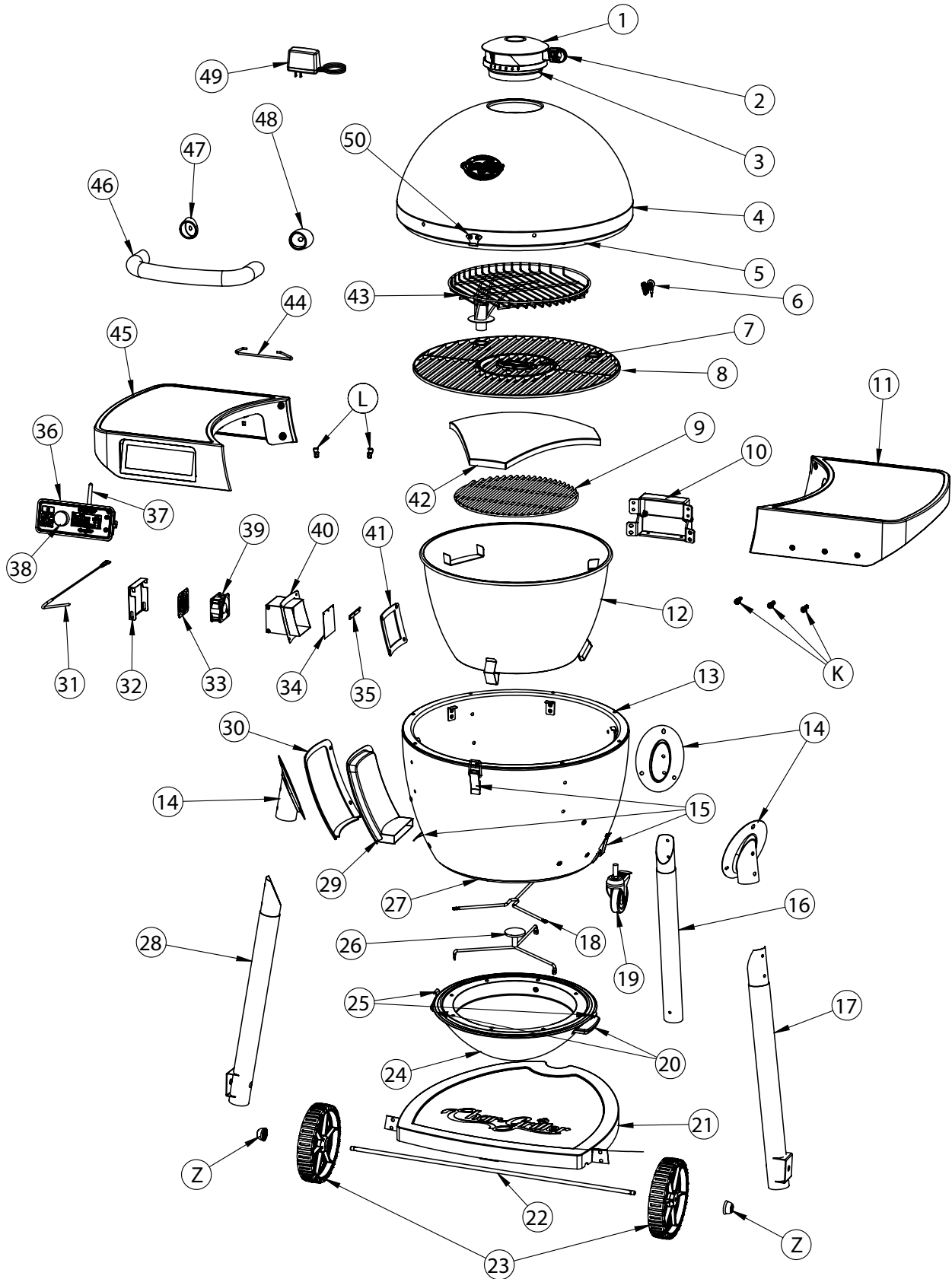



# PRE-ASSEMBLED COMPONENTS

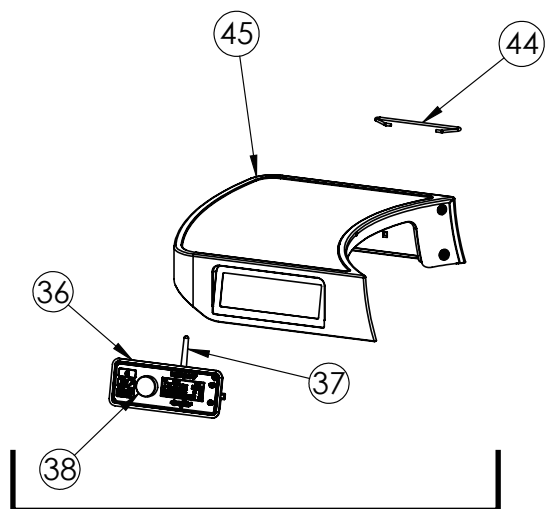

LEFT SIDE SHELF AND  
CONTROLLER ASSEMBLY

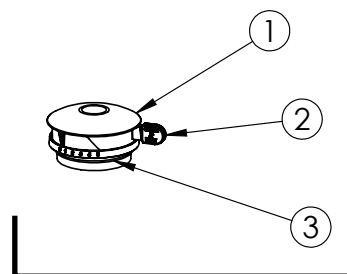

DAMPER ASSEMBLY

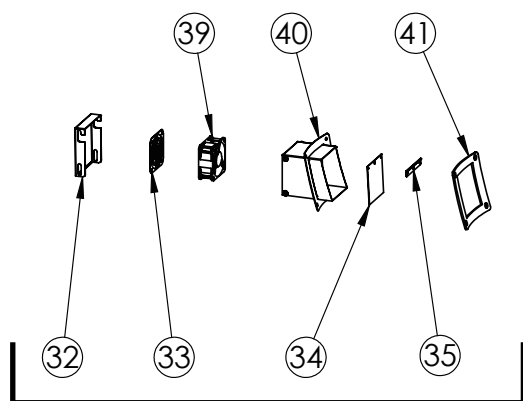

FAN ASSEMBLY

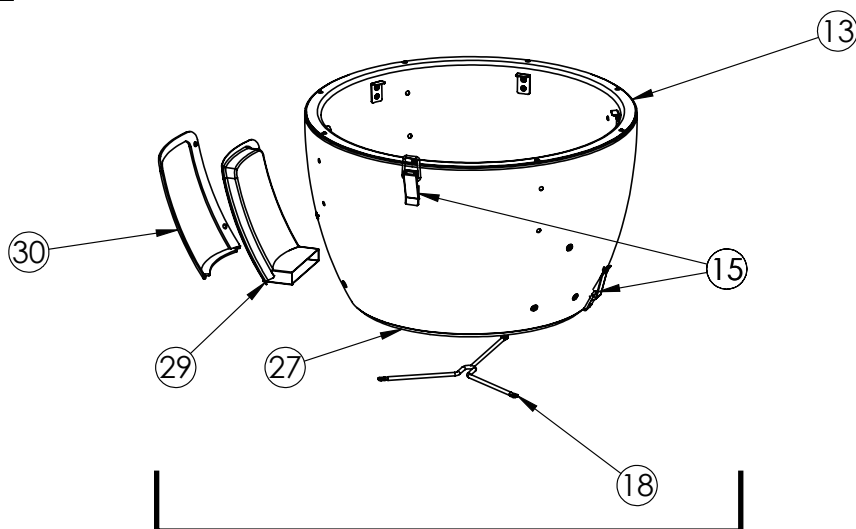

GRILL BODY ASSEMBLY

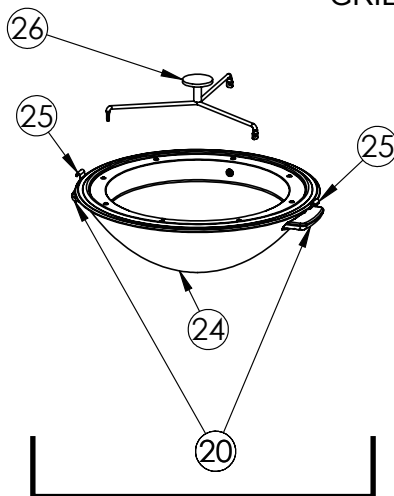

ASH PAN ASSEMBLY



# PARTS LIST











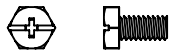



Item	QTY	Part Name
1	1	DAMPER
2	1	DAMPER HANDLE GRIP
3	1	DAMPER O-RING
4	1	HOOD
5	1	HOOD SEALER
6	1	HEAT SENSOR (HARDWARE ATTACHED)
7	1	CENTER GRATE
8	1	OUTER GRATE
9	1	FIRE GRATE
10	1	HOOD HINGE
11	1	RIGHT SIDE SHELF
12	1	FIRE BOWL
13	1	GRILL BODY
14	3	LEG SOCKET
15	3	LATCH
16	1	REAR LEG
17	1	RIGHT LEG
18	1	ASH PAN SUPPORT BRACKET
19	1	CASTER WHEEL
20	2	ASH PAN HANDLE
21	1	BOTTOM SHELF
22	1	AXLE
23	2	WHEEL
24	1	ASH PAN
25	2	ASH PAN LATCH KEEPER
26	1	ASH PAN HANGER
27	1	ASH PAN SEALER
28	1	LEFT LEG
29	1	AIR CHANNEL
30	1	AIR CHANNEL GASKET
31	1	MEAT PROBE
32	1	FAN BOX DOOR
33	1	SAFETY SCREEN
34	1	FAN FLAP
35	1	FAN FLAP SECURE BRACKET
36	1	CONTROLLER
37	1	ANTENNA
38	1	CONTROLLER KNOB
39	1	FAN
40	1	FAN BOX
41	1	FAN BOX GASKET
42	1	HEAT DEFLECTOR
43	1	WARMING RACK
44	1	POWER CORD STORAGE HOOK
45	1	LEFT SIDE SHELF
46	1	HOOD HANDLE
47	1	HANDLE LEFT BEZEL
48	1	HANDLE RIGHT BEZEL
49	1	POWER CORD
50	1	LATCH KEEPER
K	3	UTENSIL HOOK
L	2	WIRE CLIP
Z	2	HUB CAP

# HARDWARE NEEDED

**Assembly:** Requires 2 people. **Tools Needed:** Hammer, Phillips Head Screwdriver, Pliers, and a 7/16" Nut Driver.

**\*\*NOTE: DO NOT fully tighten any bolts until instructed to do so. Tightening too soon may prohibit parts from fitting together. All hex nuts should be on the inside of the grill unless stated otherwise. Unpack all contents in a well cleared and padded area.\*\***

**Estimated Time:** 45 minutes

<b>Part No.</b>	<b>Description</b>	<b>Photo</b>	<b>QTY</b>
<b>A</b>	HEX BOLT 1/4-20 X 1/2"		22
<b>B</b>	HEX BOLT 1/4-20 X 1 3/4"		8
<b>C</b>	HEX BOLT 1/4-20 X 3/4" WITH LOCKING COMPOUND		4
<b>D</b>	LOCK WASHER 1/4"		13
<b>E</b>	FLAT WASHER 1/4"		10
<b>F</b>	FLAT WASHER 2/5"		2
<b>G</b>	FIBER WASHER 1/4"		8
<b>H</b>	LARGE COTTER PIN		2
<b>I</b>	WING BOLT, 1/4-20 X 2"		2
<b>J</b>	M5 SCREW		4
<b>K</b>	UTENSIL HOOKS		3
<b>L</b>	WIRE CLIP		2
<b>M</b>	SELF TAPPING SHEET METAL SCREW		2
<b>Z</b>	HUB CAP		2



**Hardware Pack: #551241**

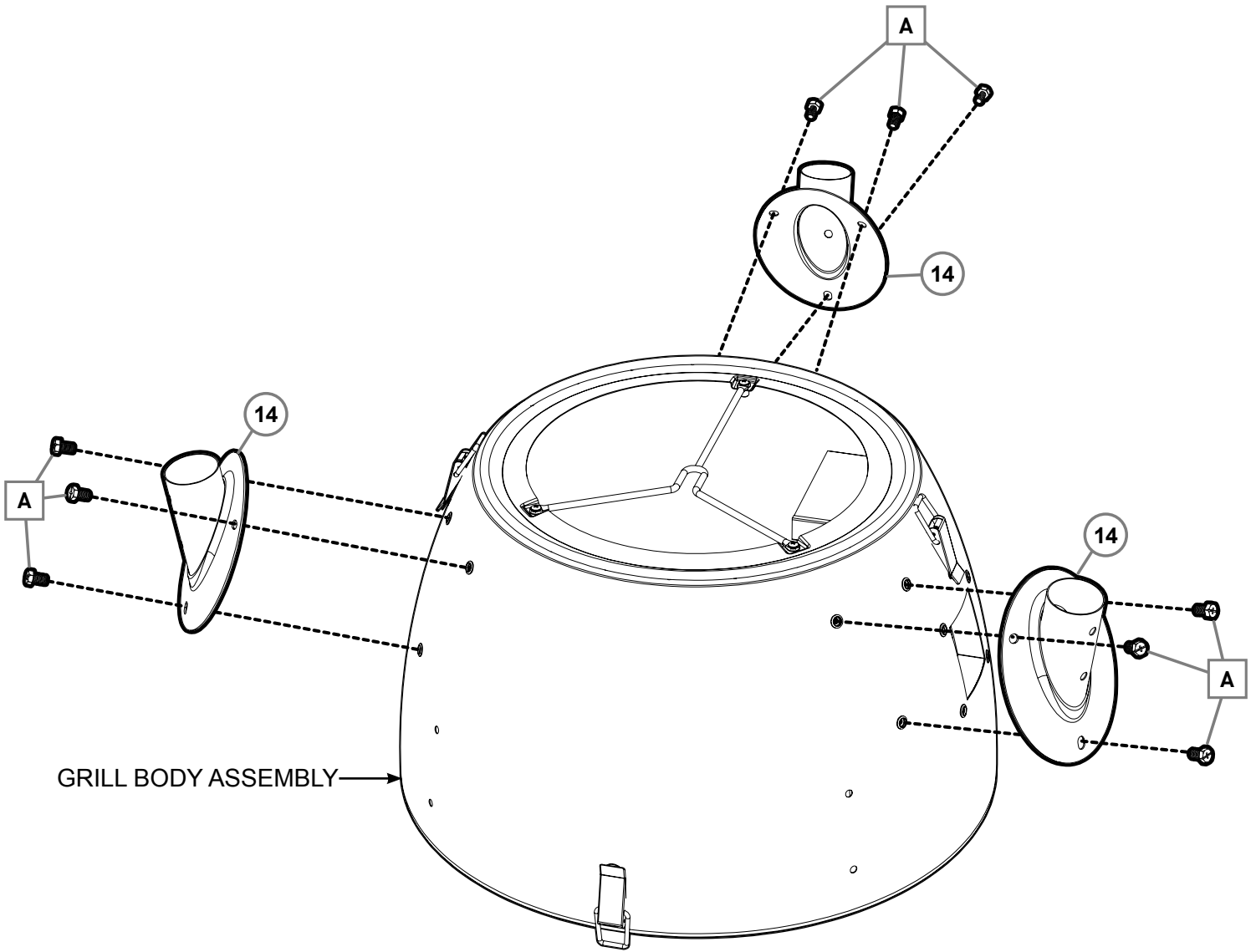
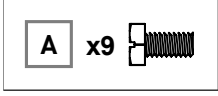

**STEP 1**



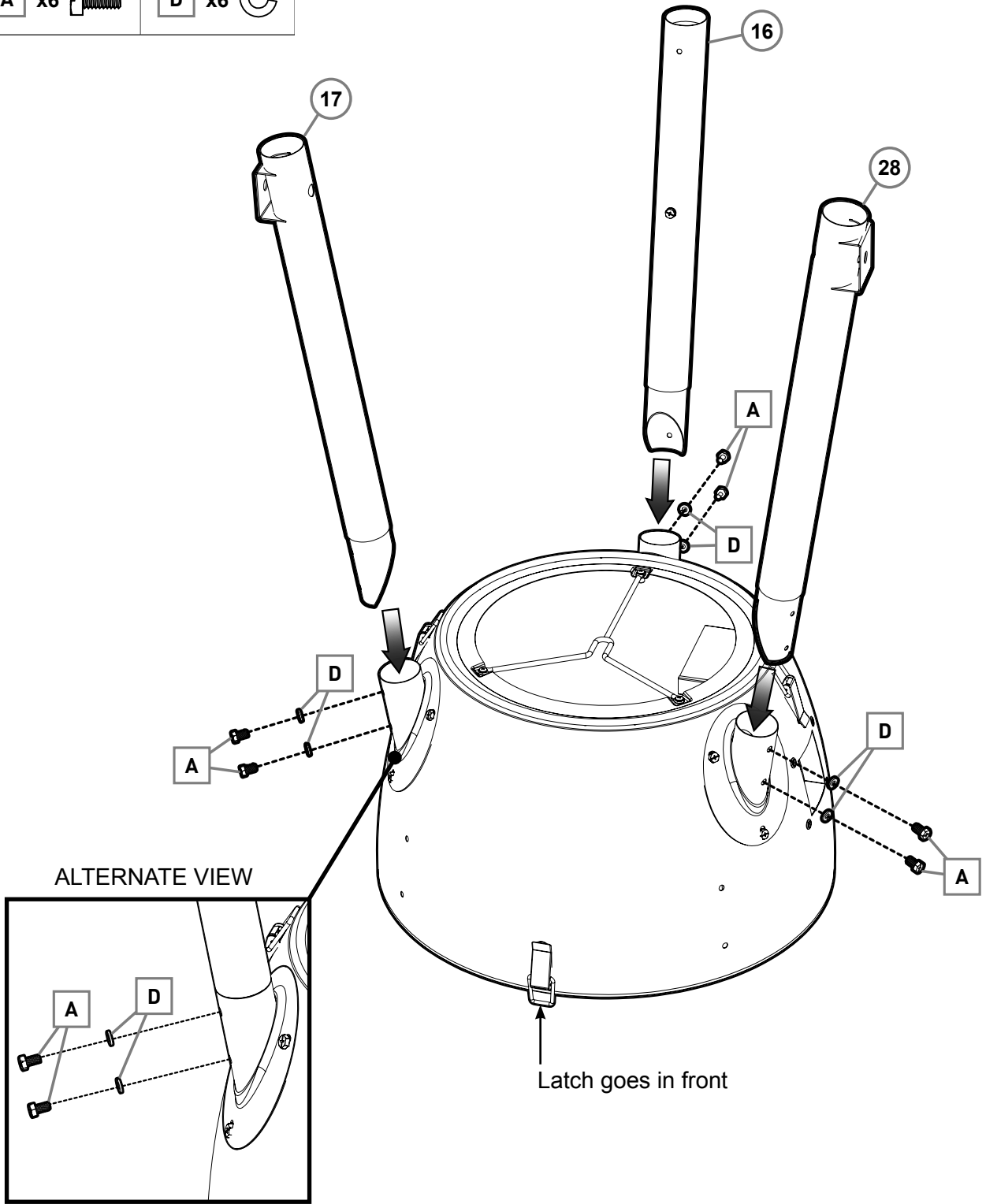

**STEP 2**

A x6 	D x6 
--	--





**STEP 3**

A x5 	D x5 
--	--

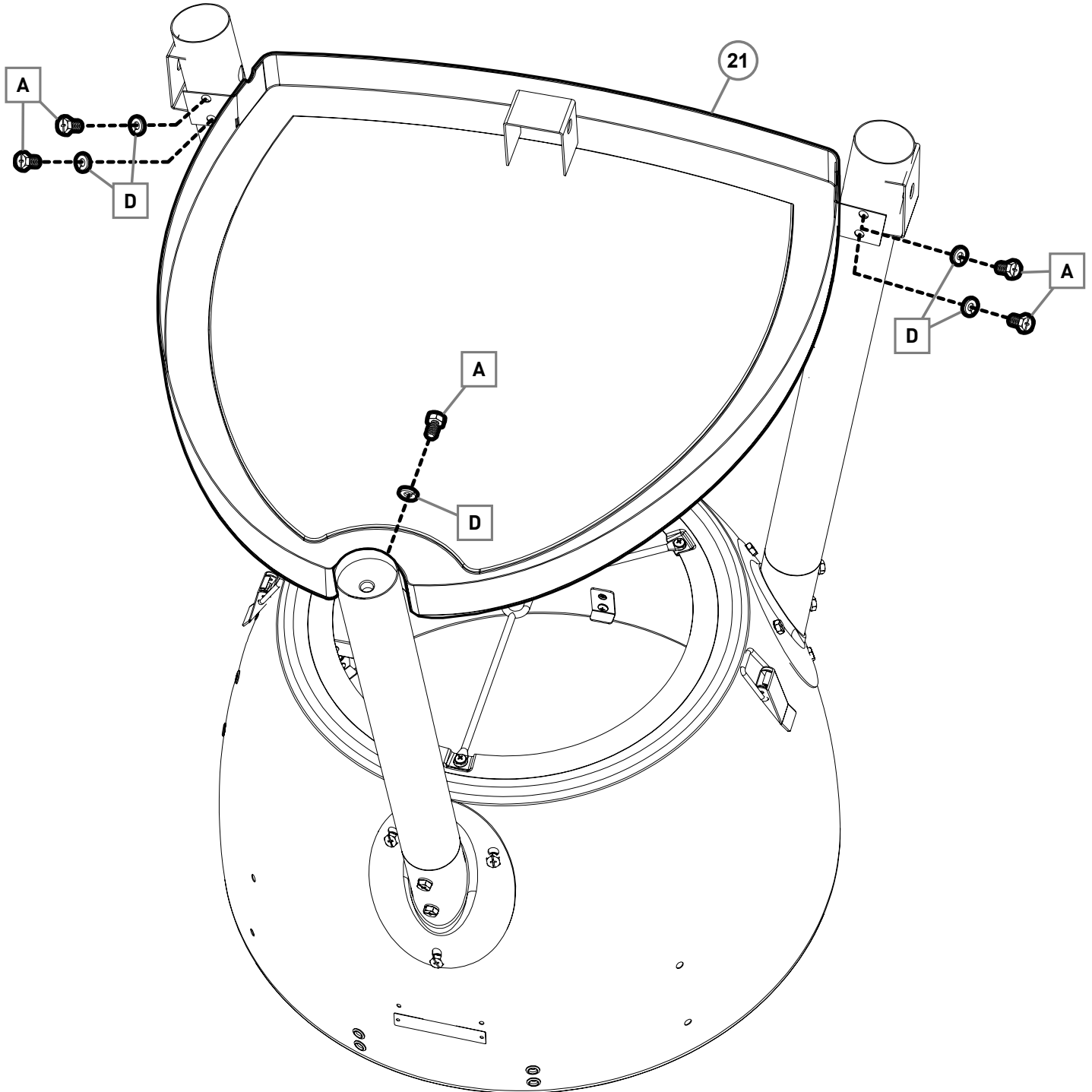

**STEP 4**

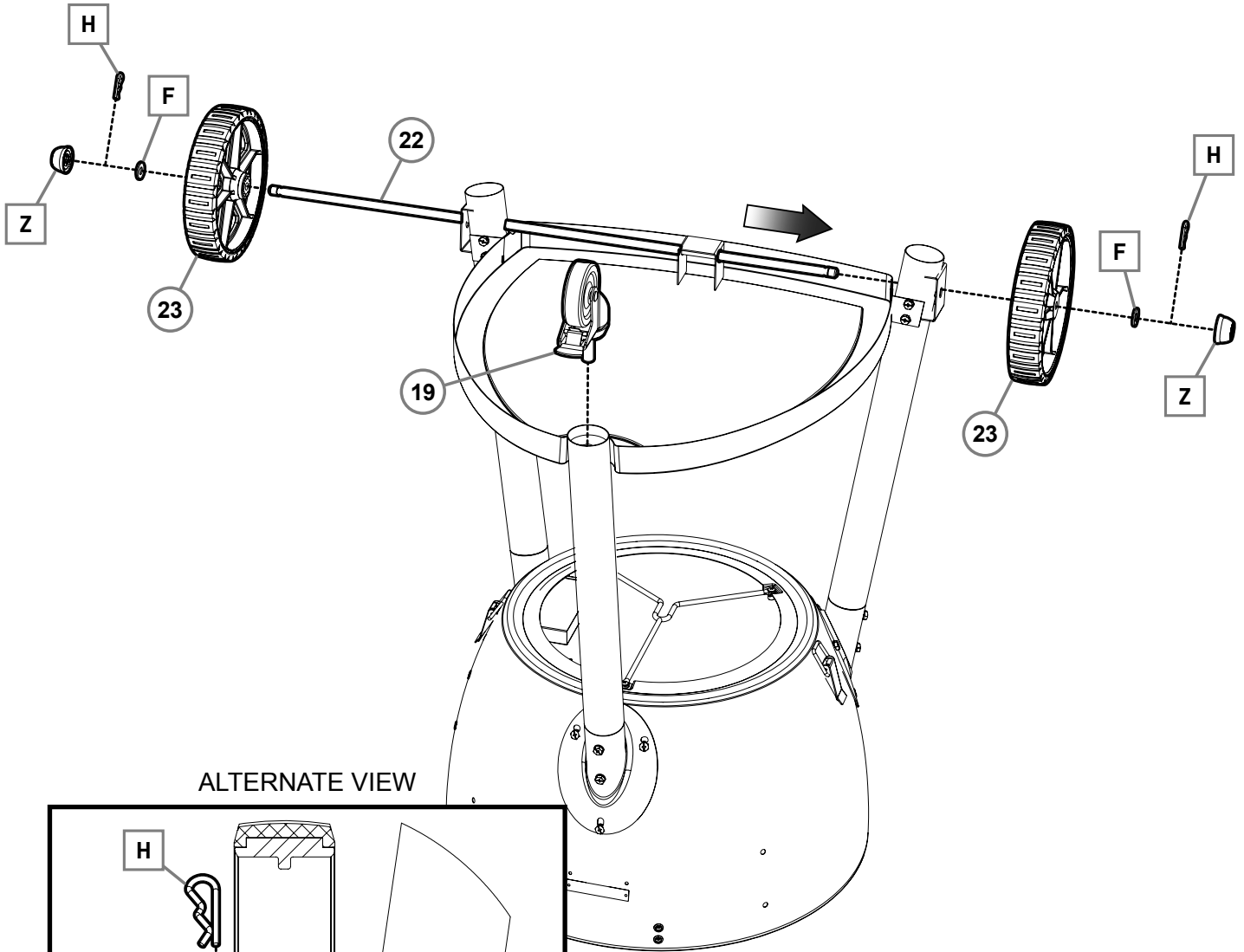
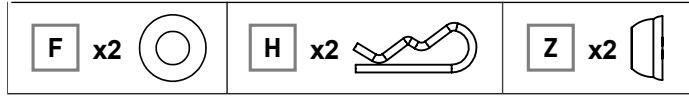

ALTERNATE VIEW

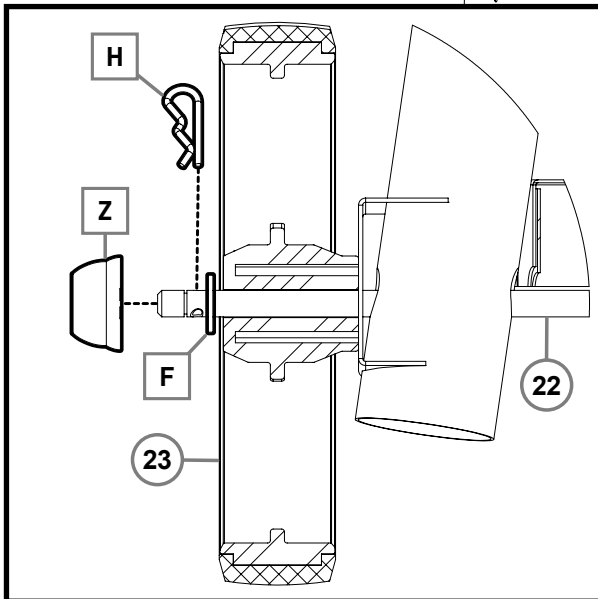



**STEP 5**

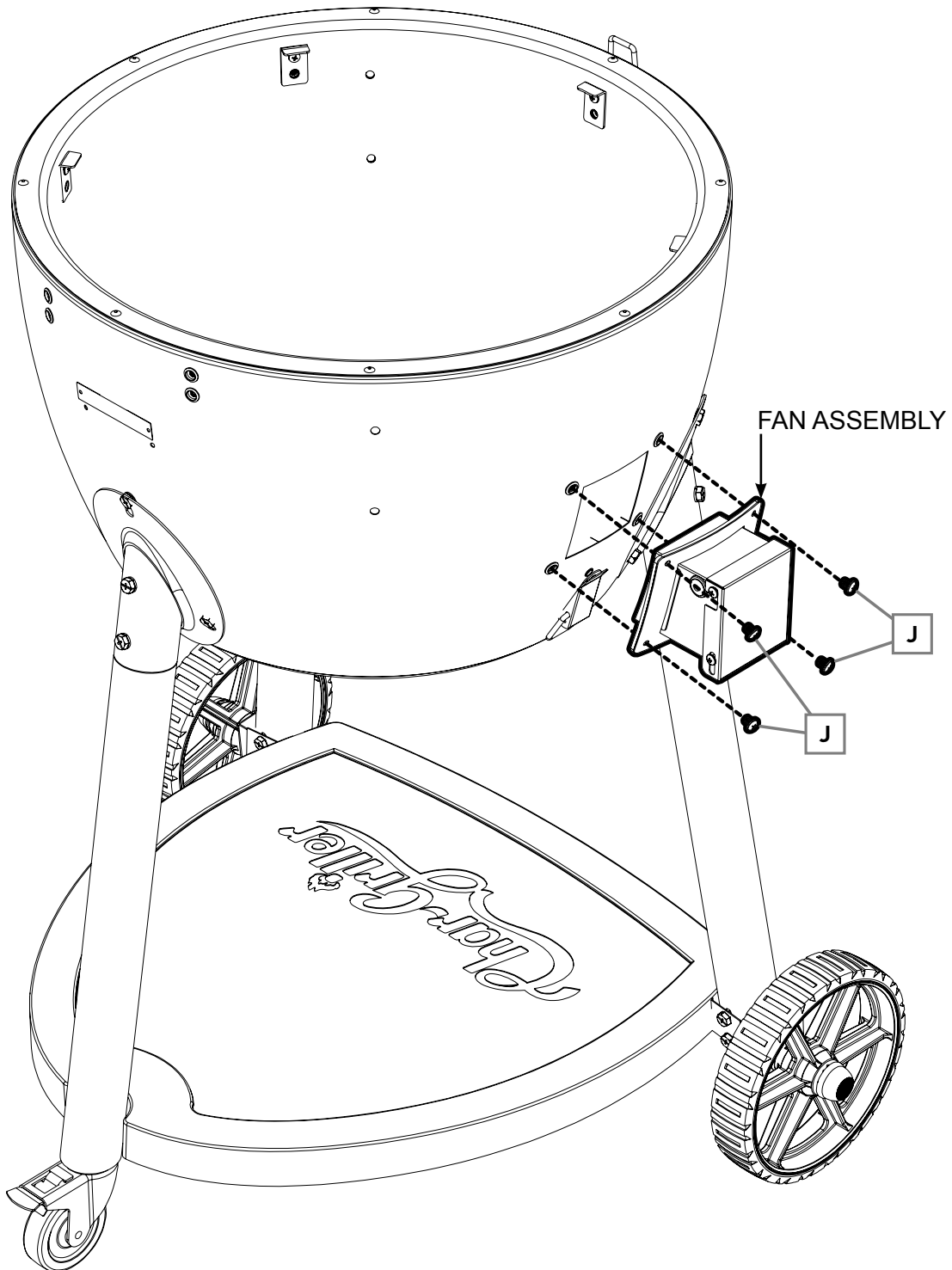
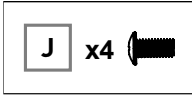



**STEP 6**

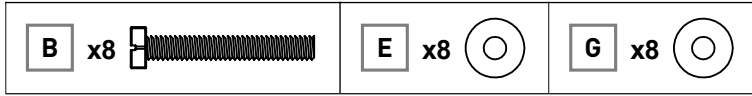

LEFT SIDE SHELF AND  
CONTROLLER ASSEMBLY

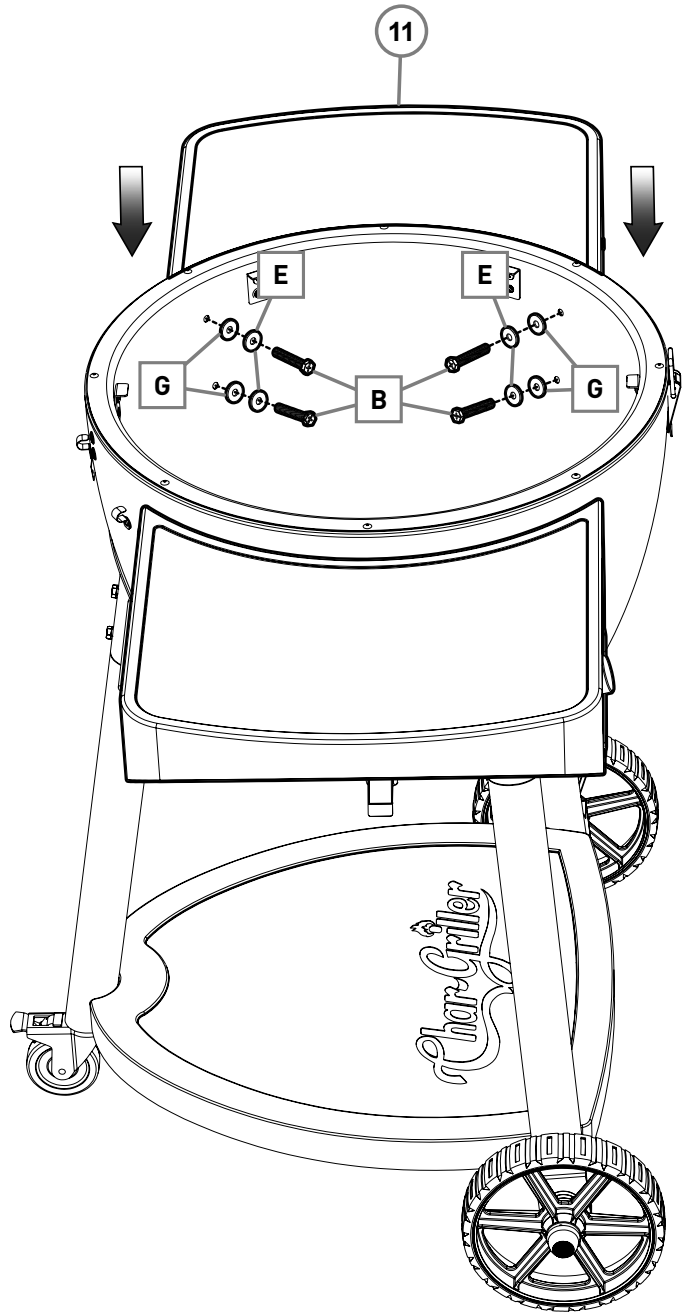
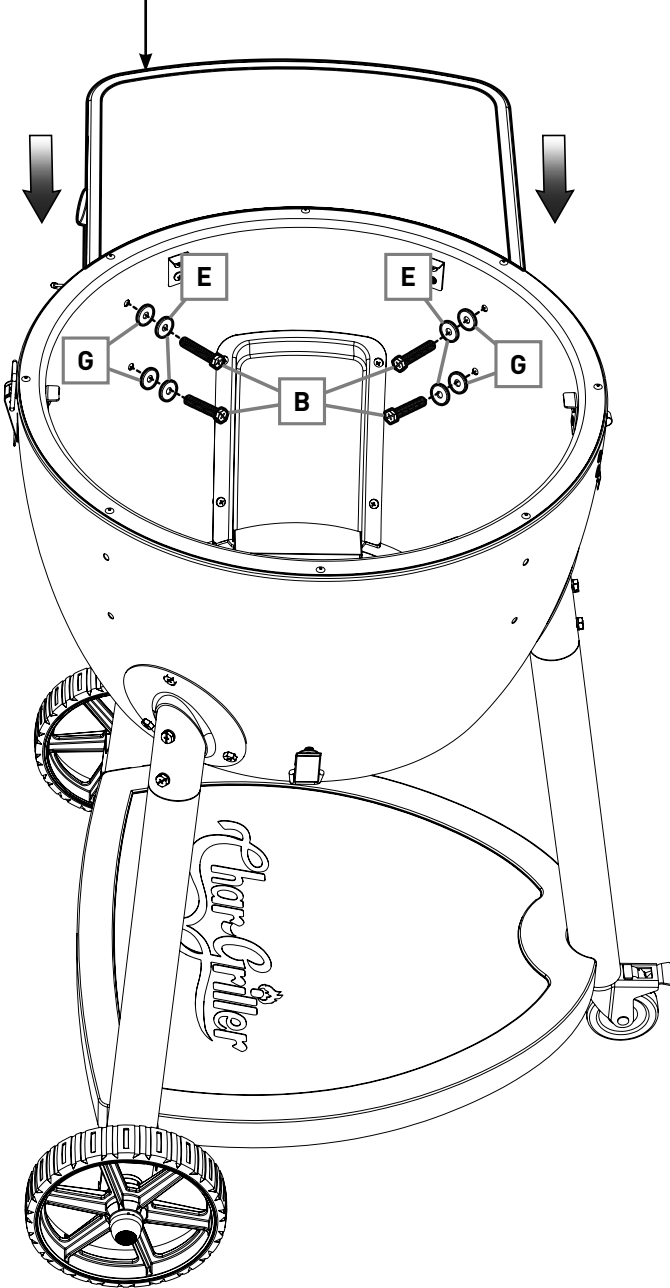



### STEP 7A

Hardware comes pre-installed on the Heat Sensor.

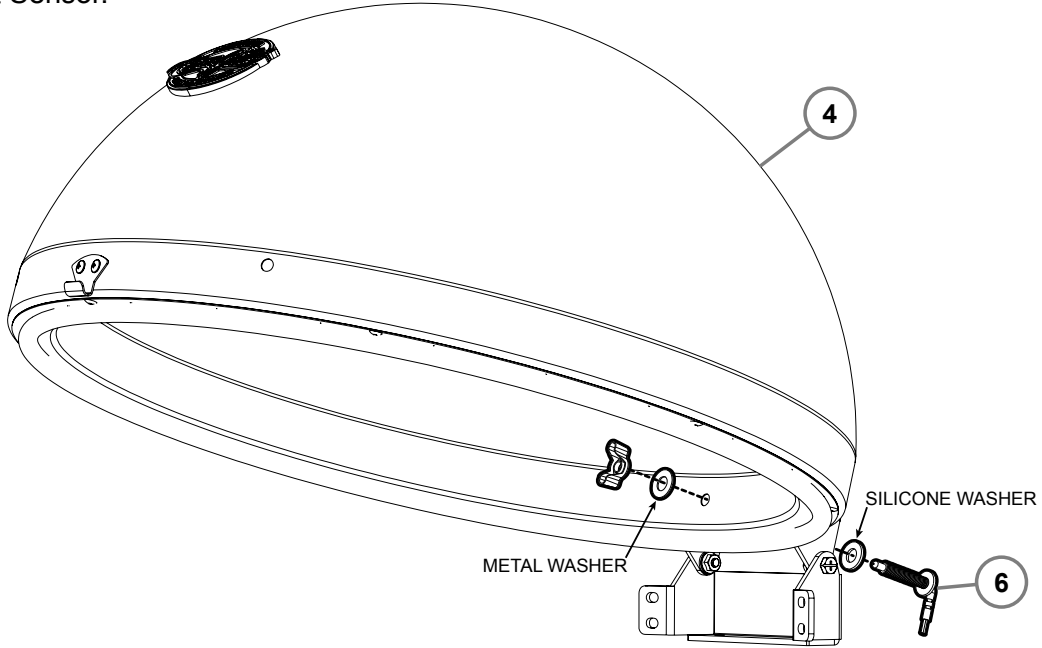

### STEP 7B

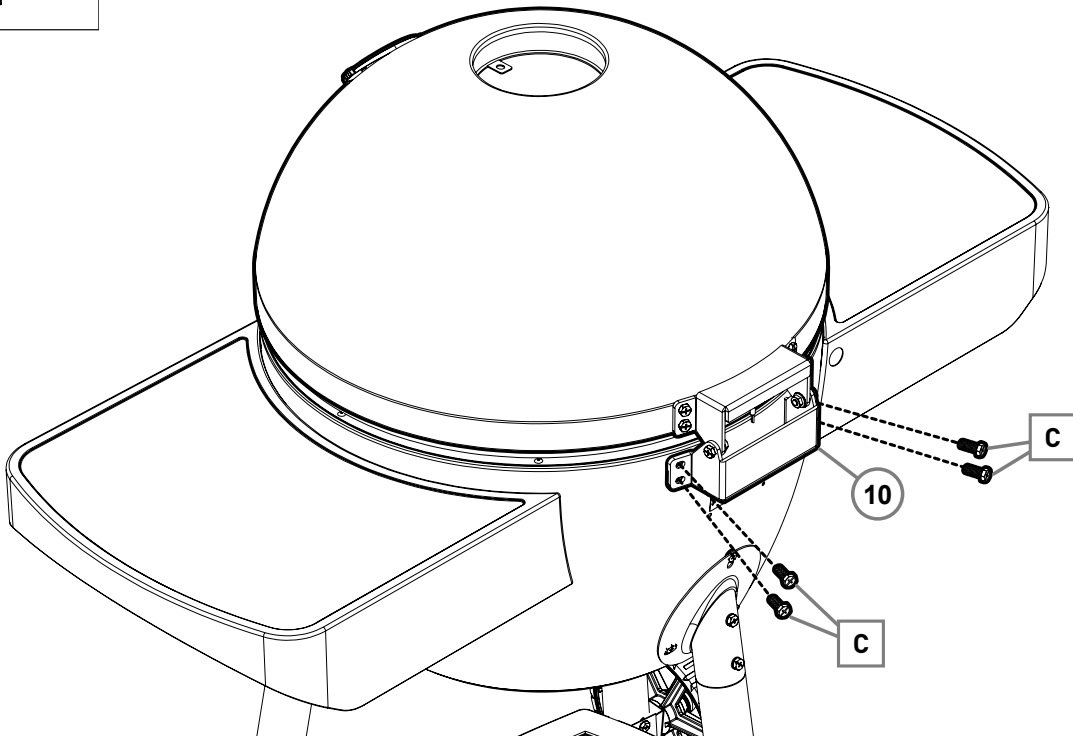
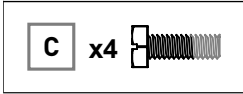

**STEP 8**

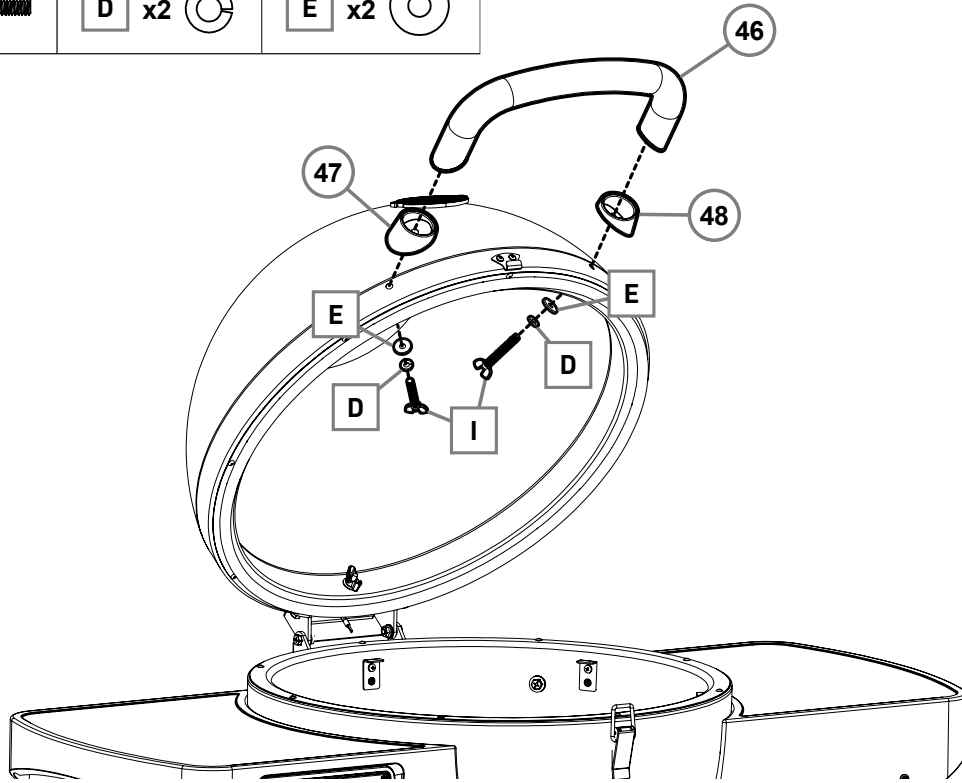
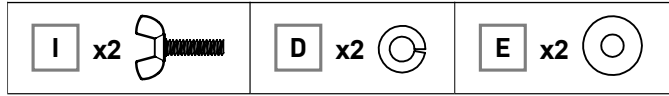

**STEP 9**

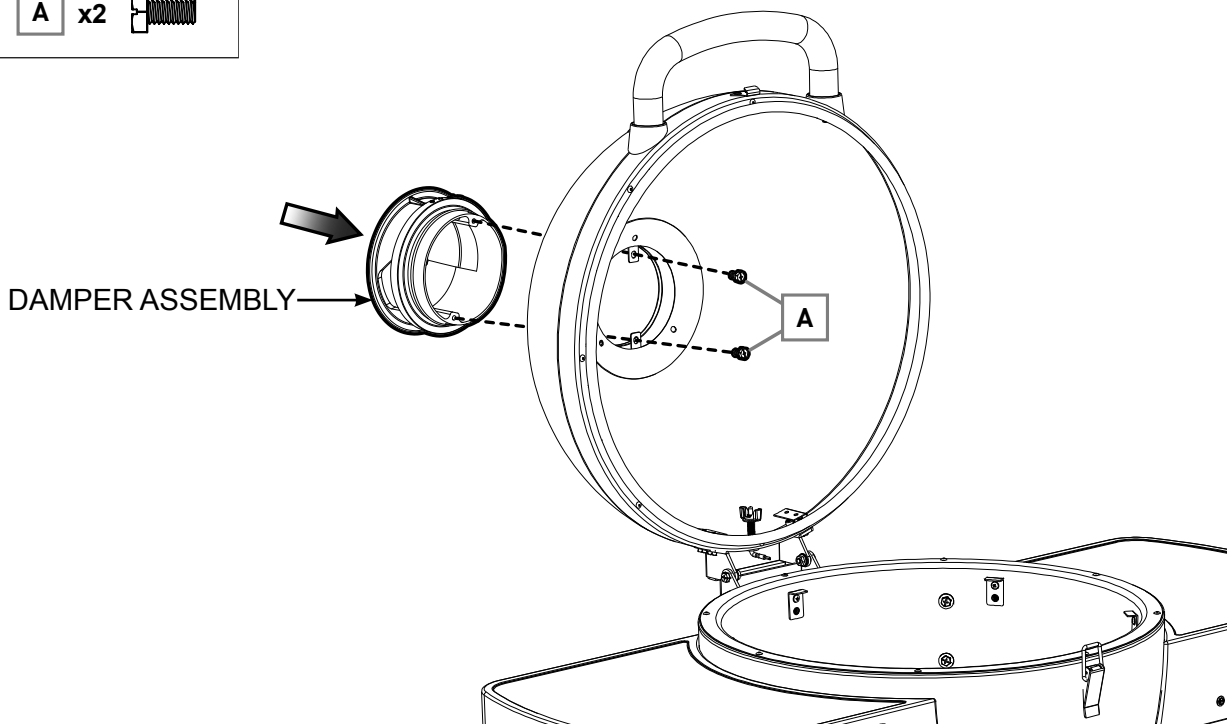
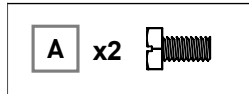

**STEP 10**

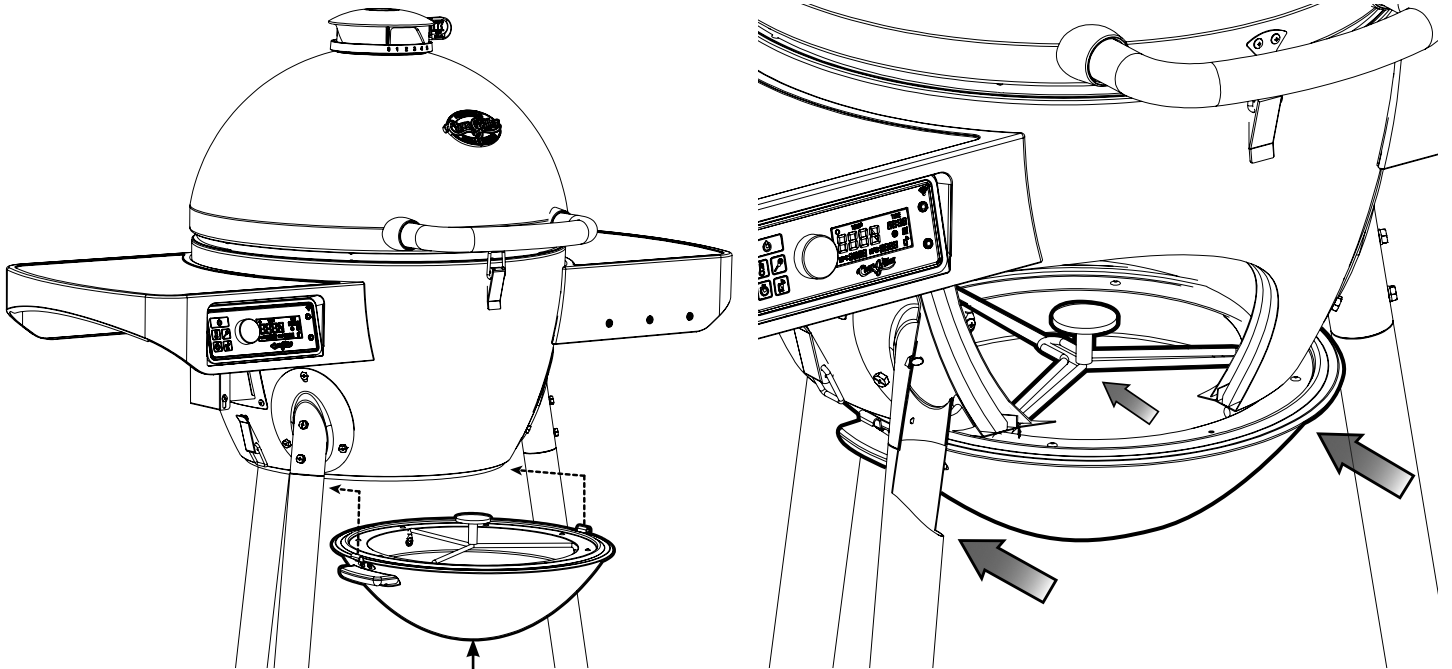

ASH PAN ASSEMBLY

ALTERNATE VIEW:  
Secure Ash Pan Assembly into  
place with the two latches.

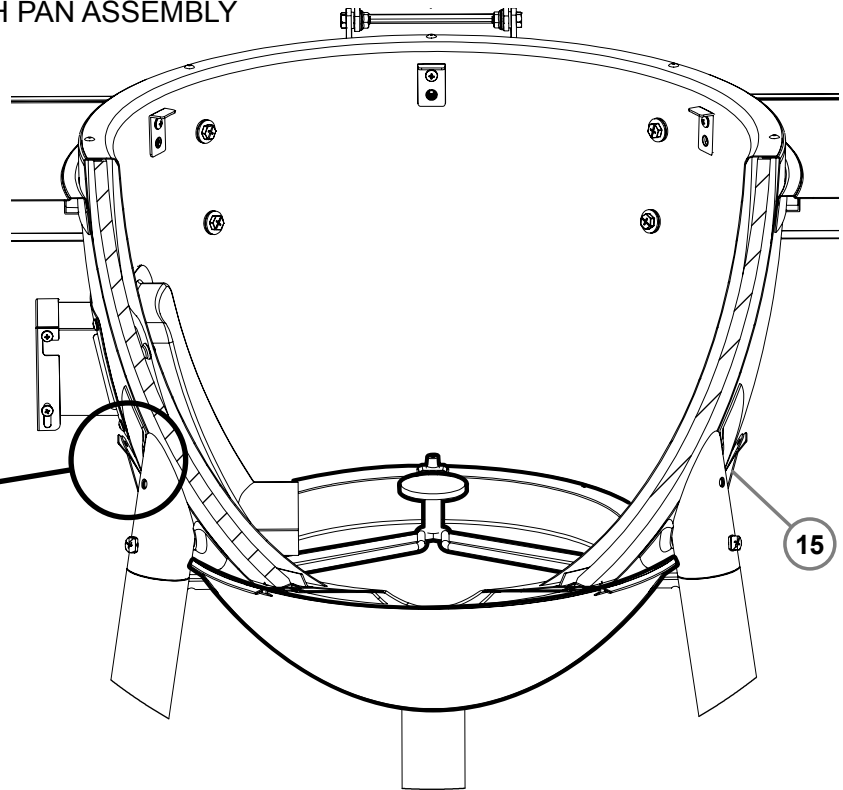
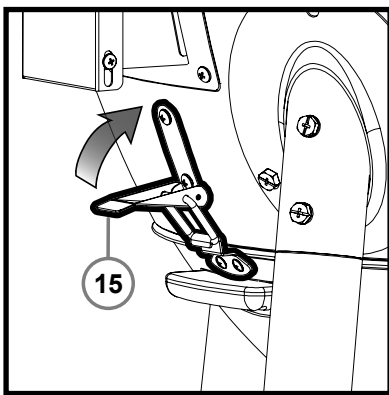

**STEP 11A**

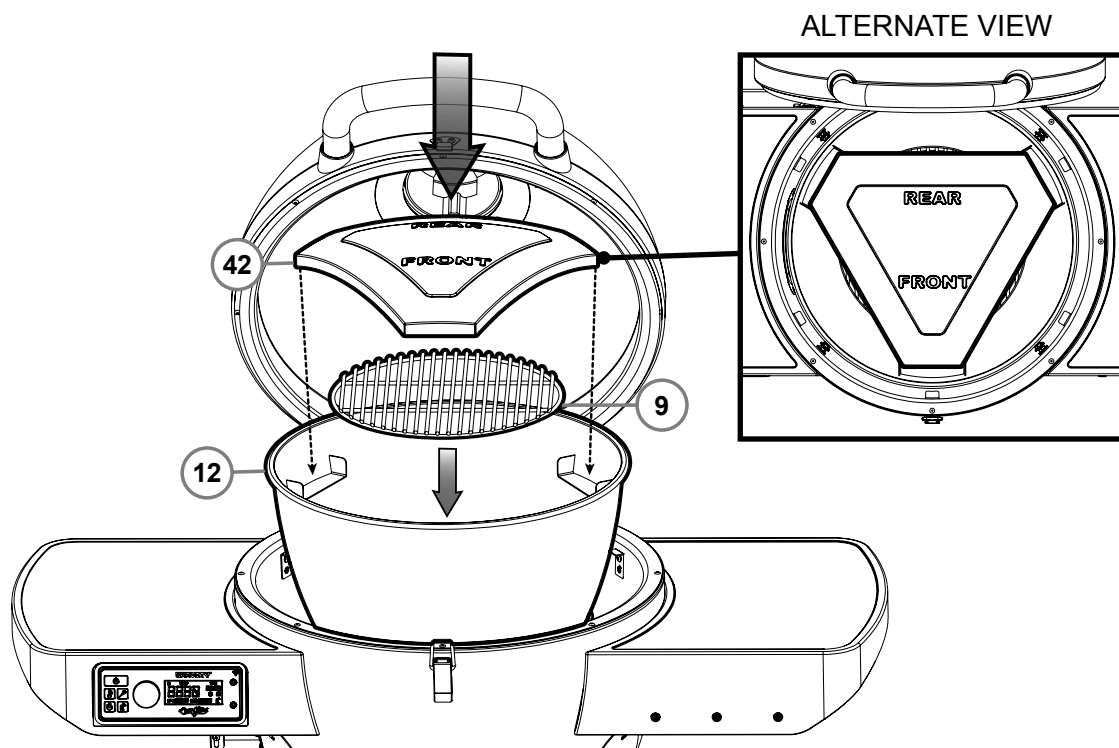

**STEP 11B**

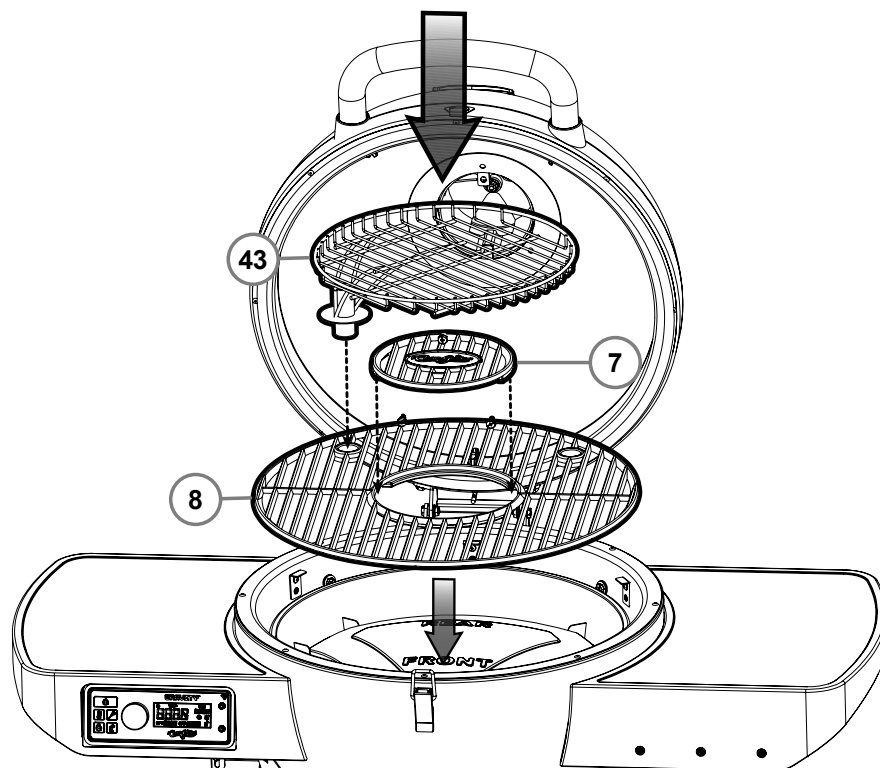



**STEP 12**

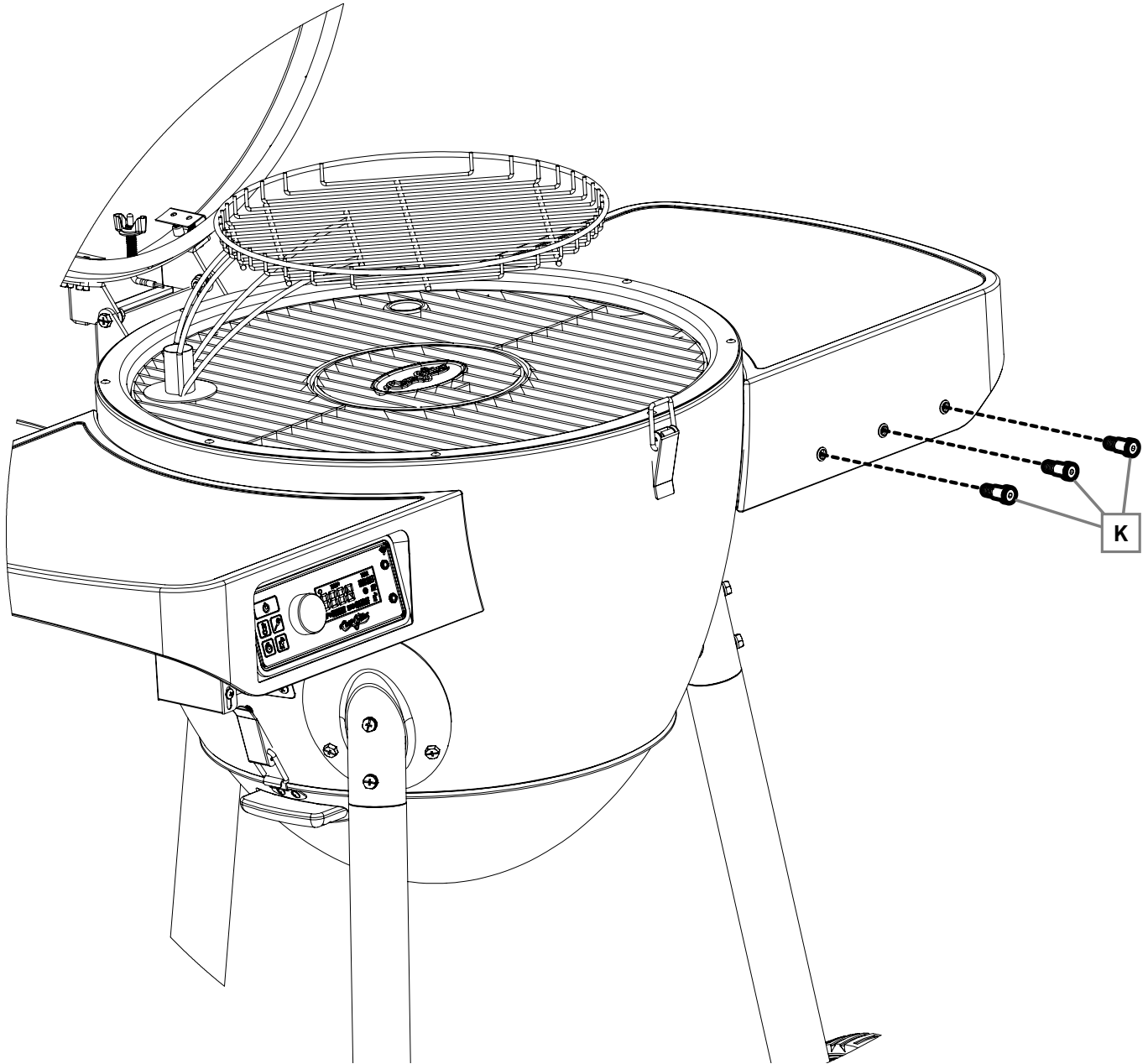
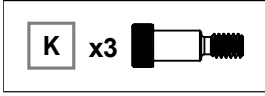

### STEP 13A

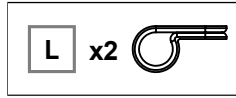

Insert the Heat Sensor Cord into the Wire Clip.

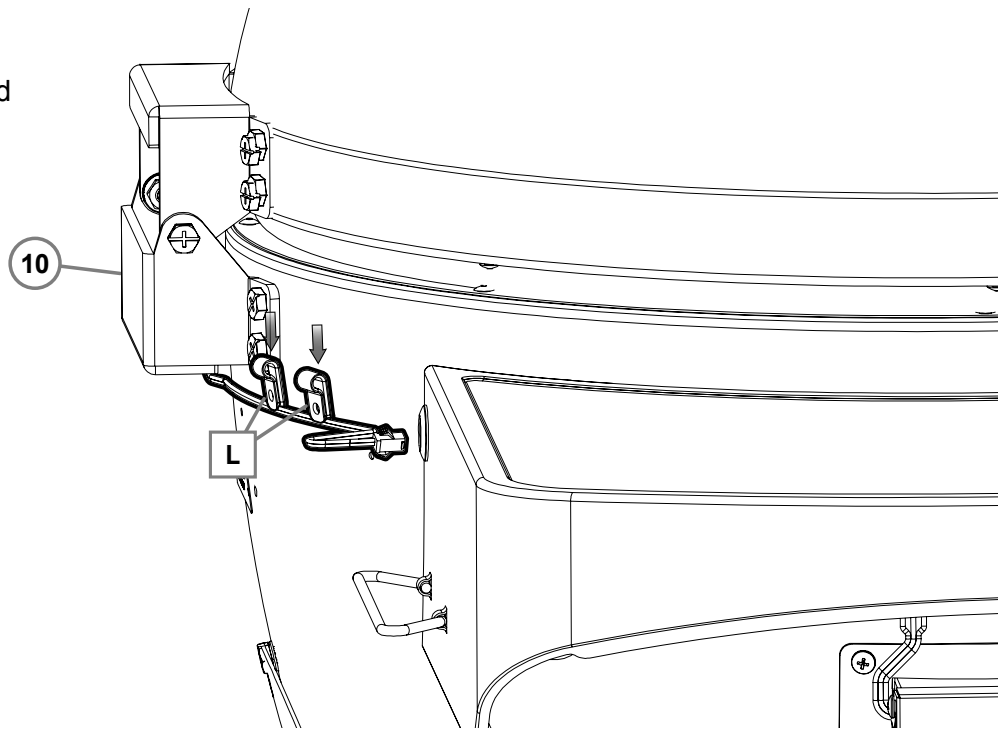

### STEP 13B

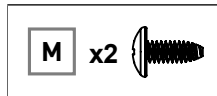

With cord inserted, secure wire clips to the grill. Feed the Heat Sensor cord through the hole in the side shelf.

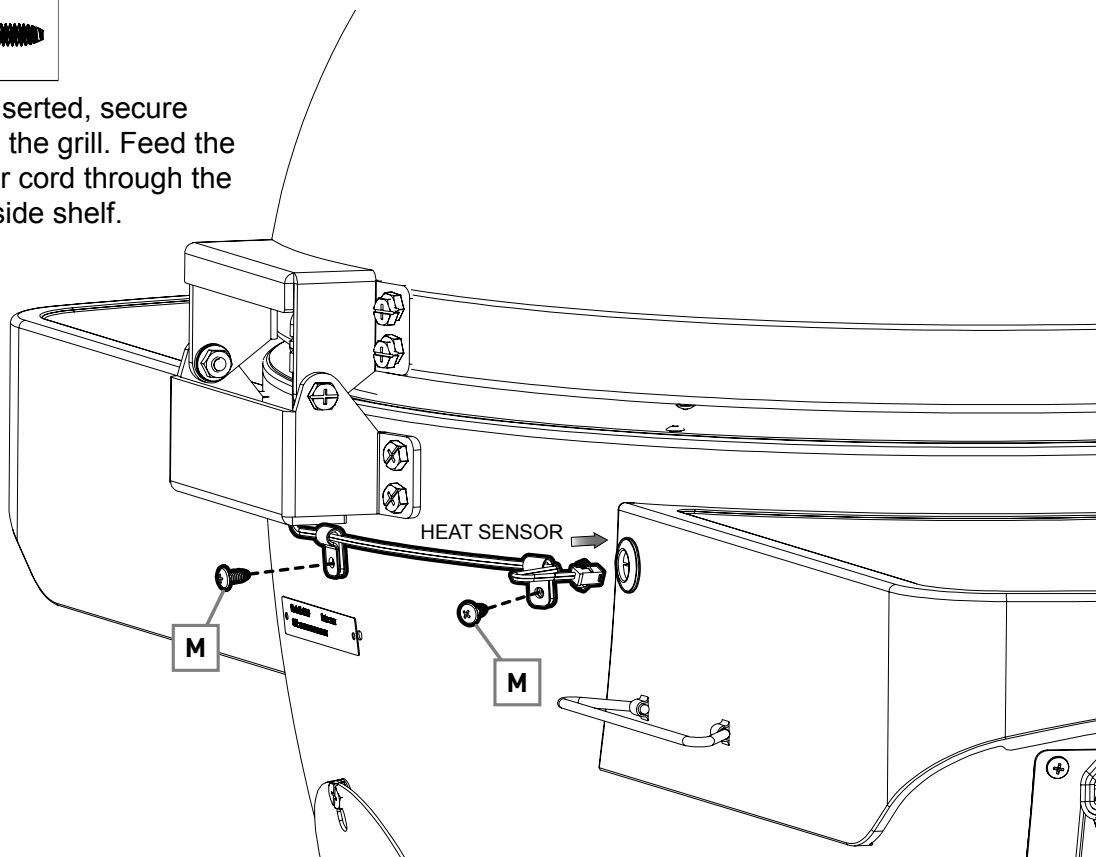



**STEP 14**

Feed the Power Cord through the hole in the side shelf.

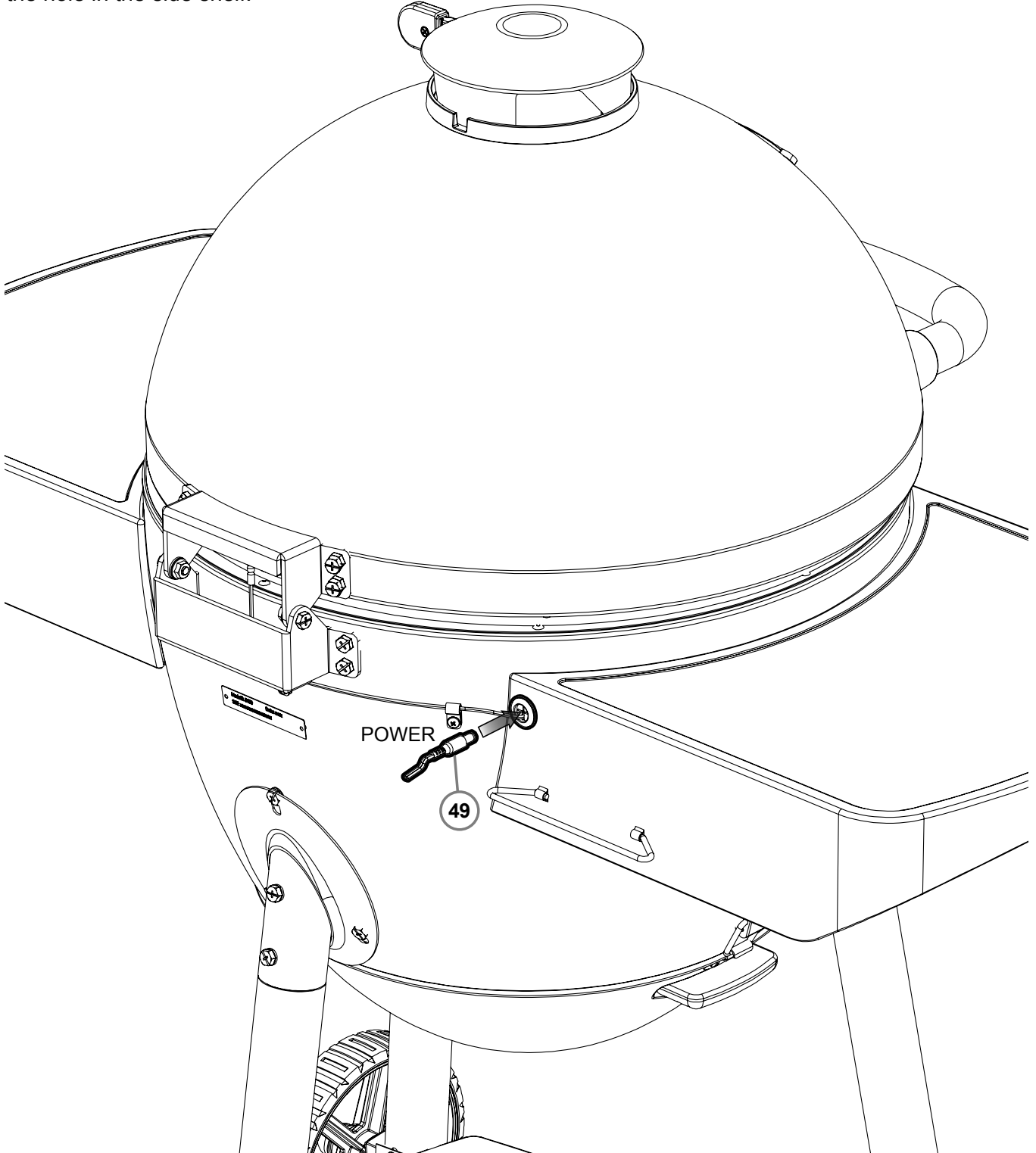



**STEP 15**

Connect all 3 Electrical Ports  
as shown.

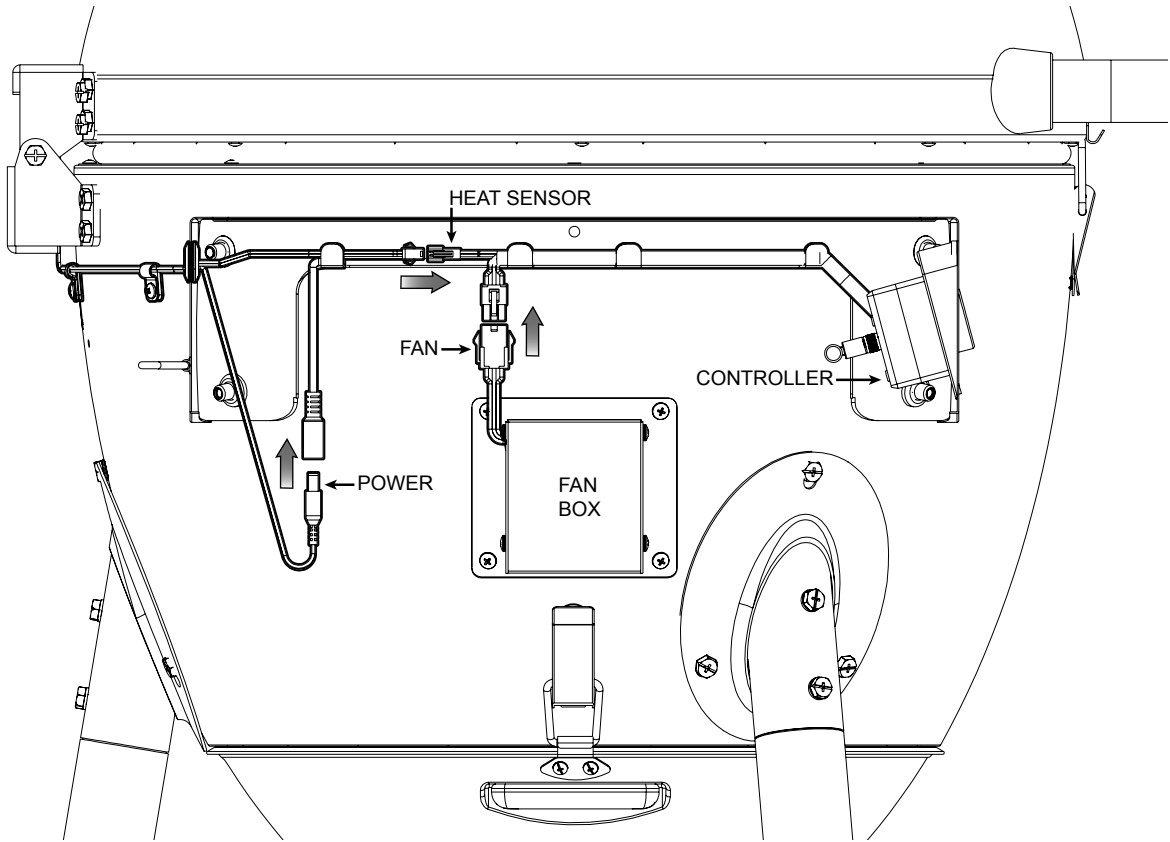

ALTERNATE VIEW

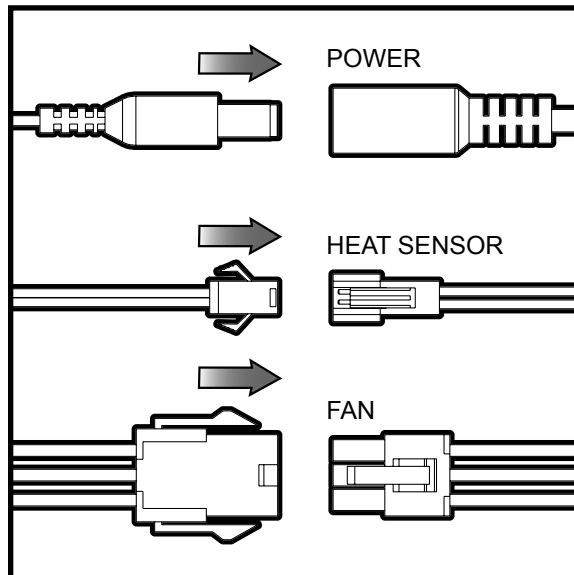



# FULLY ASSEMBLED

To ensure sturdy assembly, tighten all NUTS and BOLTS.



**GET TO KNOW  
YOUR AKORN®  
SCAN HERE**

# OPERATING INSTRUCTIONS

## Setting Up

This grill is designed for use outdoors, away from any flammable materials. It is important that there are no overhead obstructions and that there is a minimum distance of 12 feet (~4 meters) from the grill. It is important that the ventilation openings of the grill are not obstructed.

The grill must be used on a level, stable surface. The grill should be protected from direct drafts and positioned or protected against direct penetration by any trickling water (e.g. rain). Do not move grill while hot and do not leave unattended during operation.

Follow basic electrical safety precautions for outdoor appliances including: 1) Use only approved GFCI electrical outlet. 2) Do not plug appliance in until fully assembled and ready for use. 3) Do not expose electrical connections to rain or water at any time. 4) Place cords out of walkways to avoid tripping hazards. 5) Ensure all extension cords are rated for outdoor use. 6) Employ a licensed electrical contractor to address any additional concerns for safe installation and operation.

**NEVER EXCEED 700°F BECAUSE THIS WILL DAMAGE THE FINISH AND CONTRIBUTE TO RUST. PAINT IS NOT WARRANTED AND WILL REQUIRE TOUCH-UP. THIS UNIT IS NOT WARRANTED AGAINST RUST.**

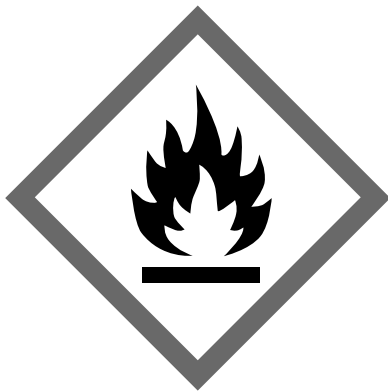

**PATENT PENDING**

**C-1**



# Lighting Instructions

- **BE PATIENT.** AKORN® Kamados are a highly efficient design, position the fuel source directly in the firebox, and require minimal airflow. This design is sensitive to the activation of the charcoal. Follow lighting and operating instructions for best performance.
- Always season your grill before first use (see page C-13).

TEMPERATURE SETTING	HEAT STYLE	ACTIVATION TIME	FUEL AMOUNT	FIRE STARTER POSITION	FIRE STARTER AMOUNT	DAMPER SETTING
<b>SMOKE</b> 200-250°F	<b>INDIRECT</b>	<b>20-30 MINS</b>	<b>1-2 LBS</b>	<b>TOP</b>	<b>1</b>	 <b>D-1</b>
<b>GRILL</b> 255-350°F	<b>DIRECT</b>	<b>20-30 MINS</b>	<b>2 LBS</b>	<b>TOP</b>	<b>1-2</b>	 <b>D-2</b>
<b>BAKE</b> 355-450°F	<b>INDIRECT</b>	<b>15-20 MINS</b>	<b>2-3 LBS</b>	<b>BOTTOM</b>	<b>2</b>	 <b>D-3</b>
<b>SEAR</b> 555-700°F	<b>DIRECT</b>	<b>15-20 MINS</b>	<b>2-3 LBS</b>	<b>BOTTOM</b>	<b>2</b>	 <b>D-5</b>

## Bottom Ignition

Place 1-2 fire starters near the bottom of the pile and cover with charcoal.

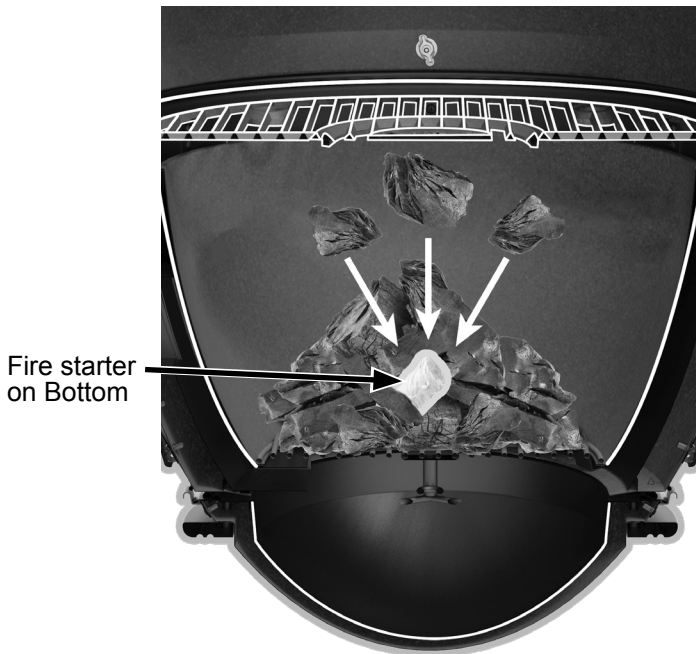

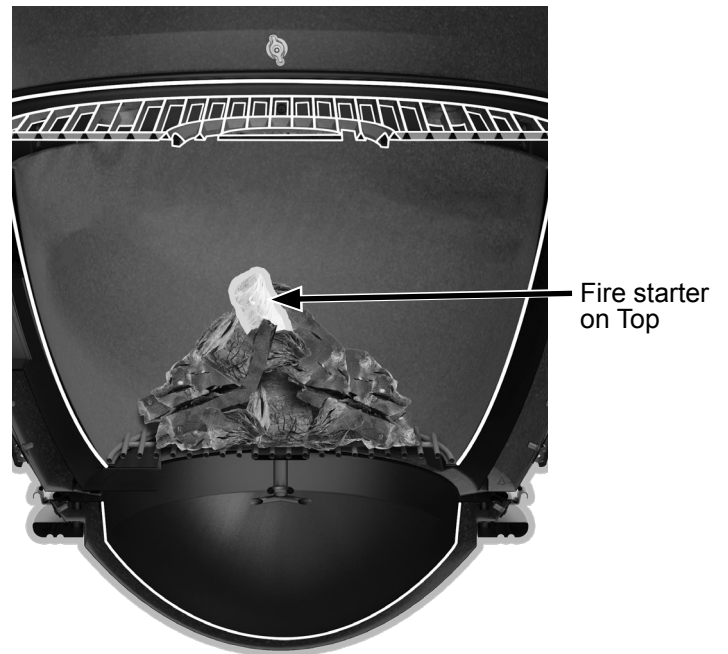

## Top Ignition

Place 1 fire starter at the top of the pile between 2 pieces of charcoal.



**Note:** Fire starter can have significant impact on reaching set temperature and how much charcoal is activated. Using more fire starters will increase the speed in reaching desired temperature, but also results in more charcoal being activated which can make it difficult to control temperatures.

- We recommend using Lump Charcoal because it contains no additives or fillers. This makes for more efficient burning, less ash and better tasting food than charcoal briquettes.
- When cooking at temperatures 350°F and below use larger pieces of charcoal. Smaller pieces can activate quicker and cause the grill to overshoot desired temperature.
- Carefully follow the lighting instructions, specifically the location of the fire starters. This allows our proprietary algorithm to strategically fan the flame and reach your desired temperature.

1. Open the lid, remove the cooking grates and heat deflector.
2. Stack Charcoal into a pyramid in the center of the fire grate. Place fire starter as described. See the chart on page C-2 for reference.
3. Open the fan cover.
4. Without changing the placement from Step 2, ignite the fire starter. Leave the lid open and allow 3-5 minutes for the fire starter to begin igniting the coals.
5. If desired, place the heat deflector. Reinsert grates, close the lid and ensure the power cord is securely plugged into a GFCI Outlet.
6. Press the Power  button for one second to turn on the controller.
7. Press the Grill Temperature  button, turn dial to desired temperature, and press dial to select.
8. The controller will display a suggested damper setting for 5 seconds, adjust as needed.

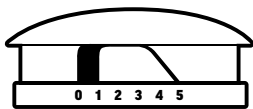

**D-1 = 200°-250°F**

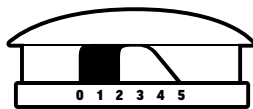

**D-2 = 255°-350°F**

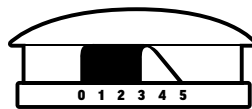

**D-3 = 355°-450°F**

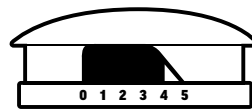

**D-4 = 455°-550°F**

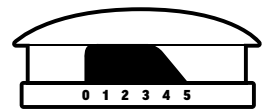

**D-5 = 555°-700°F**

Once temperature is set the fan will begin working to automatically controlling your grill temperature. Prior to use, regularly wipe down the main heat sensor. If the heat sensor gets overly dirty it can impact performance. It will take approximately 20-30 minutes for the grill to reach your desired temperature. Once temperature is reached, you are ready to cook. See Set Meat Probe Temperature, Set Timer, and Manual Fan Control on Pages C-10 – C-11 to take full advantage of your Auto-Kamado™ Features.



## NOTES:

- DO NOT USE CHARCOAL CHIMNEY TO START CHARCOAL. Over-activated charcoal will not be able to be controlled by fan controller in the AKORN® Auto-Kamado™. Instead use 1-2 fire starters to ignite the coals in the fire barrel.
- Outside influences that can affect product performance – outdoor ambient temperature, humidity level, direct/indirect sunlight, wind, and more. This may cause ignition to stall when lighting charcoal from the top. Add one or two small pieces of charcoal next to the fire starter to prevent this from happening.
- Fuel types, brands, and quality will vary product performance. Lump charcoal is recommended. Keep stored in a dry space. Charcoal that has a high moisture content will take longer to activate slowing down the speed it gets to desired temperature.
- The more fire starters used, the quicker the desired temperature will be reached. However this can cause the temperature to overshoot and will be difficult to bring back down. When smoking, 1 fire starter positioned at top of charcoal is recommended, 1-2 for baking. When grilling or searing 1-2 fire starters positioned 1-3” into the charcoal pile is recommended.
- Controller will automatically maintain your set temperature target for duration of cook.
- Set temperature is a target and some fluctuation is normal. (+/-5%) Any significant fluctuation may be the result of outside temperature, humidity, direct sunlight, moisture in fuel, incorrect damper setting, incorrect starting method, lid being open, or other factors.
- If desired, all settings can be updated after your cook has started.
- Make sure the ash pan is empty prior to starting grill fan.
- Fan door should remain open for the duration of the cook, close only when shutting down.
- Do not use gasoline, kerosene, lighter fluid or alcohol for lighting charcoal. Use of any of these or similar products could cause an explosion possibly leading to severe bodily injury.
- Char-Griller® recommends a fire starter made of solid material (wood, paper, etc.).
- Top Damper will have a suggested setting on the controller based on the temperature, this may be adjusted as needed for enhanced smoking and heating performance. When damper opening is reduced, smoke and heat will be retained in the cooking chamber for longer periods of time. This can extend fuel performance.

**Note: This may alter grill's ability to maintain the controller set temperature.**

- When in use, grill will be hot. Do not touch areas of grill, except handles, without heat resistant gloves. ALWAYS FOLLOW CHARCOAL AND FIRE STARTER MANUFACTURERS' INSTRUCTIONS AND WARNINGS. USE OUTDOORS ONLY ON NONCOMBUSTIBLE SURFACE – 12' AWAY FROM WOOD AND COMBUSTIBLE MATERIAL.
- Add water soaked hardwood chips or chunks to your charcoal for a smoked flavor. See Adding Wood For Flavor on page C-6.
- Empty ashes after each use once the grill has cooled down completely. Ashes left in bottom too long hold moisture and will rust through any thickness of steel. This grill is made of steel and cast iron, which WILL RUST, ESPECIALLY IF NOT PROPERLY CARED FOR.
- Do not use self-starting charcoal or lighter fluid as it will be difficult to manage temperature and will cause unnatural flavors.
- After each use, coat flaxseed or other food grade oil on the interior grates to reduce rust.
- Prior to use, regularly wipe down the main heat sensor. If the heat sensor gets overly dirty it can impact performance.



## ATTENTION!

Please Review ALL of the Lighting Instructions Prior to Operating Grill



- **DO NOT** use a charcoal chimney to ignite charcoal. Over-activation of charcoal will prevent controller from being able to control temperature.
- **BE PATIENT.** Time to reach desired temperature will vary by fuel type, number of fire starters and placement, as well as weather conditions. See Lighting Instructions on pages C-2 – C-5.
- Use **ONE** fire starter for smoking (200-250°F).
- **TWO** fire starters can be used to achieve higher temperatures (350-700°F).
- The appropriate fuel amount must be added to reach desired temperature. See Lighting Instructions on pages C-2 – C-5.
- When smoking (200-250°F), if the grill exceeds the set temperature by +50°F it may be challenging to reach desired temperature.
- It is **NOT** possible to go from Grilling or Searing (350-700°F) to Smoking temperatures (200-250°F). Grill must be shut down, charcoal extinguished, and restarted 1-2 hours later.
- **DO NOT** set temperature to higher than desired temperature in an attempt to reach desired temperature faster. This will result in over activating the charcoal and inability to maintain the desired temperature.
- **DO NOT** use the Heat Deflector at temperatures higher than 450°F.



## Grilling Styles

Your AKORN® Auto-Kamado™ can be used to sear, bake, grill, or smoke your food. By using the digital controller, charcoal and wood flavor, you can customize your culinary experience as desired. The following descriptions provide two of the most common ways you can cook with your AKORN™ Auto-Kamado charcoal grill and smoker.

### Direct Heat

Grill and Sear with Direct Heat at high temperatures (325° - 700°F).

1. Prepare up to 2-3 lb of lump charcoal in the center of the fire grate. Refer to the Lighting Instructions on page C-2 – C-5.
2. Make sure the heat deflector has been removed. Once the grill is at the desired temperature, you may begin to cook by placing food directly onto the cooking grates.
3. Food can cook quickly. Cook each side 3-4 minutes and then bring to desired internal temperature.

**NOTE:** Wood chips or chunks may be used in addition to charcoal to add smoke flavor as desired. Refer to page C-7 Adding Wood For Flavor.

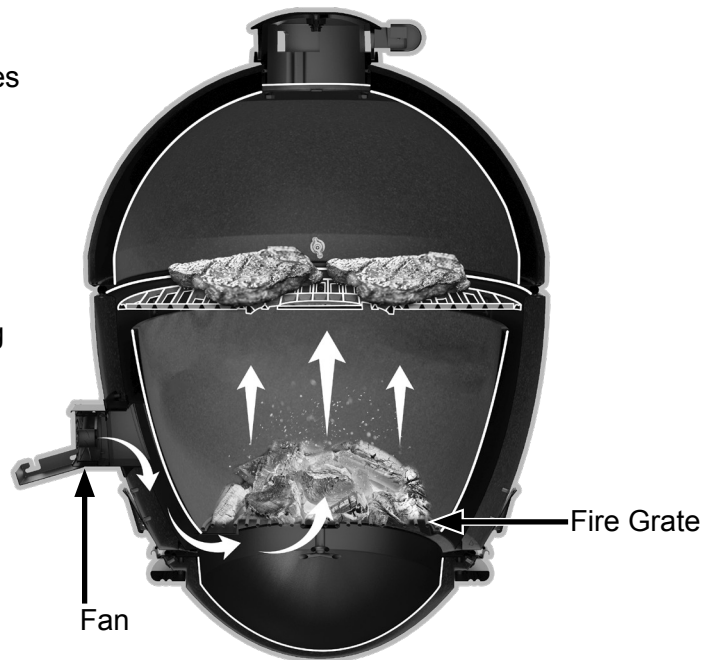

### Indirect Heat

Smoke and Bake with Indirect Heat at low temperatures (200° - 450°F).

1. Prepare up to 1-3 lb of lump charcoal in the center of the fire grate. Refer to the Lighting Instructions on page C-2 – C-5.
2. Add wood chips, chunks, or pellets as desired to add smoke flavor. (See page C-7)
3. Place the heat deflector in the fire bowl.
4. Once the grill is at the desired temperature, begin to cook.
5. Place food on the main cooking grates or the warming rack above. Food on the cooking grates will cook faster.

**NOTE:** Opening the smoking chamber will extend cooking time.

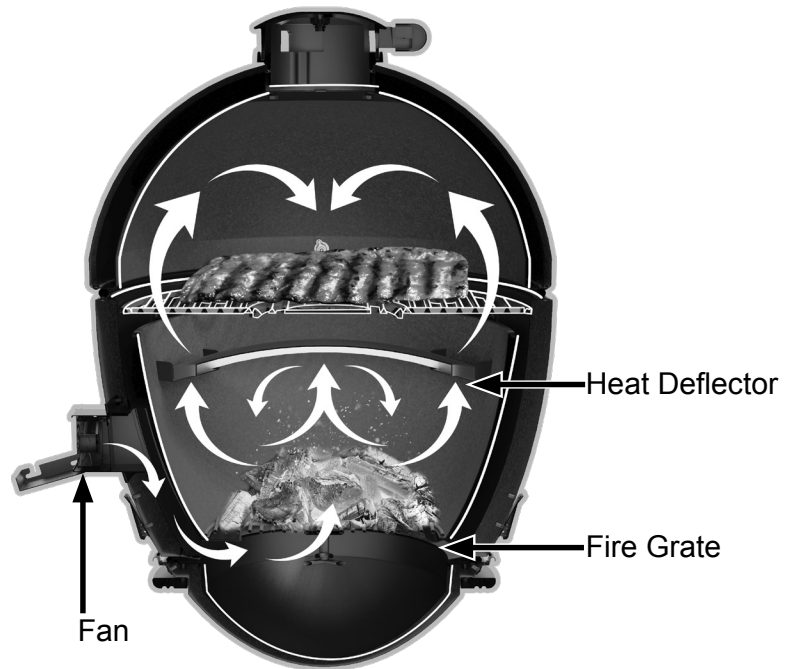





# ATTENTION!

Please Review ALL of the Lighting Instructions Prior to Operating Grill







- **DO NOT** use a charcoal chimney to ignite charcoal. Over-activation of charcoal will prevent controller from being able to control temperature.
- **BE PATIENT.** Time to reach desired temperature will vary by fuel type, number of fire starters and placement, as well as weather conditions. See Lighting Instructions on pages C-2 – C-5.
- Use **ONE** fire starter for smoking (200-250°F).
- **TWO** fire starters can be used to achieve higher temperatures (350-700°F).
- The appropriate fuel amount must be added to reach desired temperature. See Lighting Instructions on pages C-2 – C-5.
- When smoking (200-250°F), if the grill exceeds the set temperature by +50°F it may be challenging to reach desired temperature.
- It is **NOT** possible to go from Grilling or Searing (350-700°F) to Smoking temperatures (200-250°F). Grill must be shut down, charcoal extinguished, and restarted 1-2 hours later.
- **DO NOT** set temperature to higher than desired temperature in an attempt to reach desired temperature faster. This will result in over activating the charcoal and inability to maintain the desired temperature.
- **DO NOT** use the Heat Deflector at temperatures higher than 450°F.

## Adding Wood For Flavor

1. Follow the Lighting Instructions on pages C-2 – C-5.
2. Pre-soak wood chips for 35 minutes. Soak chunks for 1 hour and 30 minutes, or until the wood is completely saturated.
3. After the grill has reached the desired temperature, sprinkle two handfuls of soaked wood chips or chunks over the lit charcoals.
4. Allow the chips to smoke by closing the lid.
5. You can begin cooking after a few minutes. More soaked chips may be added to the fire later if necessary.

## Wood Pairing Guide

Different wood varieties possess different flavors and Char-Griller® recommends pairing your woods with the meats you intend to cook.

WOOD	FLAVOR	 BEEF	 PORK	 POULTRY	 SEAFOOD	 VEGGIES
ALDER	MILD			✓	✓	
MAPLE	MILD			✓		✓
CHERRY	MILD		✓	✓	✓	
APPLE	MEDIUM	✓	✓	✓	✓	
PECAN	MEDIUM	✓	✓	✓	✓	✓
OAK	MEDIUM	✓	✓	✓	✓	✓
HICKORY	STRONG	✓	✓			
MESQUITE	STRONG	✓	✓			





## Adding Charcoal

**IMPORTANT:** This grill maintains temperature by controlling the airflow into a completely sealed chamber. Opening the cooking chamber will result in additional oxygen to fuel reaching the fire, causing flames to rise. It is recommended to slowly lift the lid approximately 1/8th of the way to allow some heat to escape before fully opening the lid. Use great care when following these instructions.

**DO NOT** add charcoal when the Grill Temperature is set greater than 250°F.

**ALWAYS** wear heat resistant gloves

Do not use gasoline, kerosene, lighter fluid or alcohol for lighting charcoal. Use of any of these or similar products could cause an explosion possibly leading to severe bodily injury.

1. Pause the fan by pressing the Power  button for 1 second
2. Unlatch and carefully open the grill lid – **CAUTION: LID WILL BE HOT.**
3. Stand back from the cooking chamber as flame rises – **CAUTION: DO NOT PUT FACE OR UNPROTECTED HANDS OVER COOKING CHAMBER.**
4. Wait approximately 30 seconds for flames to equalize.
5. Using the grate lifter, carefully remove the cooking grates – **CAUTION: GRATES WILL BE HOT.**
6. Pour additional charcoal onto the fire grate.
7. Carefully return the cooking grates to the grill using the grate lifter – **CAUTION: GRATES WILL BE HOT.**
8. Close and latch lid immediately.
9. Press Power  button for one second to restart the fan and resume automated temperature control.

## Turning Grill OFF

1. **ALWAYS** wear heat resistant gloves.
2. Turn controller OFF by pressing and holding Power  button for 2 seconds.
3. Unplug grill from power source and wrap around the power cord storage hook.
4. Ensure grill lid is closed and latched.
5. Close the Top Damper and Fan Door.
6. Allow grill to cool completely, empty the ash pan, and cover with a Char-Griller® custom fit cover.



### ATTENTION!

Please Review ALL of the Lighting Instructions Prior to Operating Grill



- **DO NOT** use a charcoal chimney to ignite charcoal. Over-activation of charcoal will prevent controller from being able to control temperature.
- **BE PATIENT.** Time to reach desired temperature will vary by fuel type, number of fire starters and placement, as well as weather conditions. See Lighting Instructions on pages C-2 – C-5.
- Use **ONE** fire starter for smoking (200-250°F).
- **TWO** fire starters can be used to achieve higher temperatures (350-700°F).
- The appropriate fuel amount must be added to reach desired temperature. See Lighting Instructions on pages C-2 – C-5.
- When smoking (200-250°F), if the grill exceeds the set temperature by +50°F it may be challenging to reach desired temperature.
- It is **NOT** possible to go from Grilling or Searing (350-700°F) to Smoking temperatures (200-250°F). Grill must be shut down, charcoal extinguished, and restarted 1-2 hours later.
- **DO NOT** set temperature to higher than desired temperature in an attempt to reach desired temperature faster. This will result in over activating the charcoal and inability to maintain the desired temperature.
- **DO NOT** use the Heat Deflector at temperatures higher than 450°F.

# Using the AKORN® Auto-Kamado™ Digital Controller



- ① **Power On/Off**
- ② **Control Dial**  
Rotate to view options.  
Press to select option.
- ③ **Digital Display** (See diagram below)
- ④ **Meat Probe 1 Jack**
- ⑤ **Meat Probe 2 Jack**
- ⑥ **Meat Probe Temperature Button**
- ⑦ **Auto or Manual Fan Control Button**
- ⑧ **Timer Button**
- ⑨ **Grill Temperature Button**

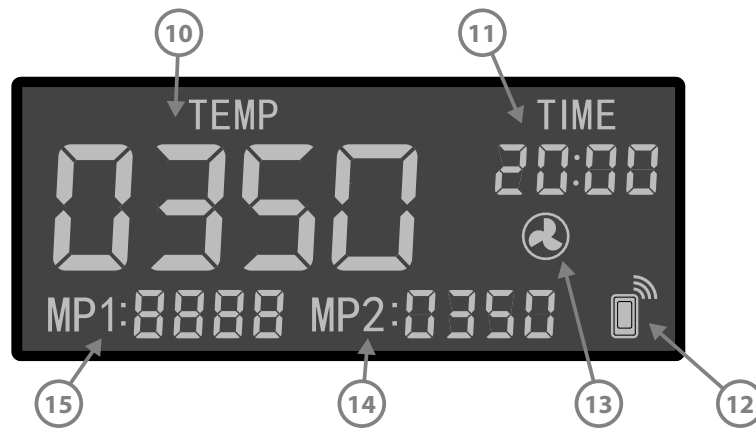

- ⑩ **Grill Temperature Display**  
Can also display other settings such as recommended damper opening.
- ⑪ **Countdown Timer**
- ⑫ **Paired with Phone**  
Icon displays when smart device connected.
- ⑬ **Fan Indicator**  
Icon displays when fan is running
- ⑭ **Meat Probe 2 Temperature**
- ⑮ **Meat Probe 1 Temperature**



## **AKORN® Auto-Kamado™ Digital Controller (Continued)**

### **POWER**

1. Ensure Controller Adapter is securely plugged in to GFCI outlet
2. Press Power Button for 1 second to turn controller ON
3. Press and hold Power Button for 2 seconds to turn Controller OFF
4. Press Power Button for 1 second when running to Pause, Press again for 1 second to Resume  
NOTE: Use the Pause Function when checking food or adding additional fuel. If Pause has been enabled for 10 minutes Controller will beep to alert user to resume or turn off grill. A push notification will also be sent to the App.

### **SET GRILL TEMPERATURE**

1. Press Grill Temperature Button
2. Adjust desired temperature target by rotating Control Knob (max 700°F)
3. Press Control Knob to select desired grill temperature target
4. Suggested Damper setting will blink for 5 seconds, set damper notch to the corresponding number

### **SET MEAT PROBE TEMPERATURE**

1. Insert Meat Probe Connector into Probe Jack (Controller can accommodate up to 2 meat probes)
2. Press Meat Probe Temperature Button
3. Adjust desired internal meat temperature by rotating Control Knob (max 225°F)
4. Press Control Knob to select desired temperature
5. Press Meat Probe Button to switch between Probes 1 & 2
6. Alarm will sound when internal temperature is reached (press any button to stop alarm)  
NOTE: Meat Probe should not be used to measure Ambient Air temperature in the grill and will be permanently damaged if it exceeds 250°F.

### **SET TIMER**

1. Press Timer Button
2. Adjust desired timer duration by rotating Control Knob  
NOTE: Timer will change in 1-minute increments, shorter increments are available by using the Char-Griller® App
3. Press Control Knob to select desired time
4. Alarm will sound when timer completes (press any button to stop alarm)

# AKORN® Auto-Kamado™ Digital Controller (Continued)

## MANUAL FAN SPEED

If desired or required during troubleshooting, you can manually set the fan speed of your AKORN™ Auto-Kamado. This will override all temperature automation features. Use manual fan control with caution, as more fan power will equal more flame and heat. Because of the efficient and insulated design, it is difficult to decrease temperature once it has increased above your ideal temperature.

1. Press the fan button.
2. Adjust desired fan speed, from 0 to 100, by rotating the Control Knob.
3. Press the knob to select the fan setting. This will override the temperature automation.
4. To return to AUTO mode, press and hold the fan button.

**NOTE:** While in manual fan mode, the grill temperature display will toggle between the fan speed and the grill temperature.



## ATTENTION!

Please Review ALL of the Lighting Instructions Prior to Operating Grill



- **DO NOT** use a charcoal chimney to ignite charcoal. Over-activation of charcoal will prevent controller from being able to control temperature.
- **BE PATIENT.** Time to reach desired temperature will vary by fuel type, number of fire starters and placement, as well as weather conditions. See Lighting instructions on pages C-2 – C-5.
- Use **ONE** fire starter for smoking (200-250°F).
- **TWO** fire starters can be used to achieve higher temperatures (350-700°F).
- The appropriate fuel amount must be added to reach desired temperature. See Lighting Instructions on pages C-2 – C-5.
- When smoking (200-250°F), if the grill exceeds the set temperature by +50°F it may be challenging to reach desired temperature.
- It is **NOT** possible to go from Grilling or Searing (350-700°F) to Smoking temperatures (200-250°F). Grill must be shut down, charcoal extinguished, and restarted 1-2 hours later.
- **DO NOT** set temperature to higher than desired temperature in an attempt to reach desired temperature faster. This will result in over activating the charcoal and inability to maintain the desired temperature.
- **DO NOT** use the Heat Deflector at temperatures higher than 450°F.



## Pairing the Grill with a Smart Device

**NOTE:** This is NOT required for basic operation.

1. Download the Char-Griller® app from the App Store (Apple or Google Play). For more information about the App, supported devices, and more - go to [CharGriller.com/akorn/app-support](http://CharGriller.com/akorn/app-support).
2. After installation is completed, open the App.
3. Bluetooth®:
  - a. Go to Settings page
  - b. Click on Bluetooth®
  - c. Select “Akorn-XXXX” from List
  - d. Pairing is complete
4. Bluetooth® + Wifi:
  - a. Go to Setting page
  - b. Click on Wifi
  - c. Select preferred wifi network from list



**NOTE:** Device only works on 2.4Ghz networks. (Device will not work on 5Ghz networks or networks that use 2.4Ghz and 5Hz frequencies simultaneously. If your wifi network does not segregate the 2.4Ghz wireless frequency, Bluetooth® will be the only connection option)

This device complies with Part 15 of the FCC Rules. Operation is subject to the following two conditions:

1. This device may not cause harmful interference, and
2. This device must accept any interference received, including interference that may cause undesired operation.

### FCC Warning

Warning: Changes or modifications to this smoker not expressly approved by the party responsible for compliance could void the user's authority to operate the equipment.

### FCC Statement

This equipment has been tested and found to comply with the limits for a Class B digital device, pursuant to part 15 of the FCC Rules. These limits are designed to provide reasonable protection against harmful interference in a residential installation. This equipment generates, uses and can radiate radio frequency energy and, if not installed and used in accordance with the instructions, may cause harmful interference to radio communications. However, there is no guarantee that interference will not occur in a particular installation. If this equipment does cause harmful interference to radio or television reception, which can be determined by turning the equipment off and on, the user is encouraged to try to correct the interference by one or more of the following measures:

- Reorient or relocate the receiving antenna.
- Increase the separation between the equipment and receiver.
- Connect the equipment into an outlet on a circuit different from that to which the receiver is connected.
- Consult the dealer or an experienced radio/TV technician for help.

*The Bluetooth® word mark and logos are registered trademarks owned by Bluetooth® SIG, Inc. and any use of such marks by (A&J Manufacturing, L.L.C.) is under license. Other trademarks and trade names are those of their respective owners.*

# Seasoning Your AKORN® Auto-Kamado™

Seasoning is the first step before you start cooking on your new grill. This process will help protect the cast iron grates, reduce food sticking to the grates, improve searing, and reduce unnatural flavors. Char-Griller® recommends using flaxseed oil for seasoning your grill but most food grade oils (canola, grapeseed, vegetable, safflower, etc) will work as well.



## STEP 1: OIL COOKING GRATE

1. Thoroughly coat both sides of the cooking grate with flaxseed or other food grade oil.
2. Prepare approx. 2-3 lb of lump charcoal on the fire grate. Follow the Lighting Instructions on page C-2 – C-5.



## STEP 2: HEAT UP GRILL

1. Following the instructions for operating the Auto-Kamado™ Controller (pages C-9 – C-11) and the lighting instructions (page C-2 – C-5).
2. Ignite the fuel, bring the temperature to approximately 350°F, and close the lid.
3. Once at temperature, allow grill surfaces to season for 20 minutes.



## STEP 3: RE-APPLY OIL TO GRATES 3X

1. After 20 minutes, pause the fan (see Power section on page C-10), open your grill and allow grates to cool.
2. Using a brush, re-coat both sides of your cooking grates with flaxseed or other food grade oil.
3. Close lid, resume the fan and allow surfaces to season for 20 minutes.
4. Repeat this process up to three times to improve the nonstick surface.
5. Your grill is now ready for use.



## ATTENTION!

Please Review ALL of the Lighting Instructions Prior to Operating Grill



- **DO NOT** use a charcoal chimney to ignite charcoal. Over-activation of charcoal will prevent controller from being able to control temperature.
- **BE PATIENT.** Time to reach desired temperature will vary by fuel type, number of fire starters and placement, as well as weather conditions. See Lighting Instructions on pages C-2 – C-5.
- Use **ONE** fire starter for smoking (200-250°F).
- **TWO** fire starters can be used to achieve higher temperatures (350-700°F).
- The appropriate fuel amount must be added to reach desired temperature. See Lighting Instructions on pages C-2 – C-5.
- When smoking (200-250°F), if the grill exceeds the set temperature by +50°F it may be challenging to reach desired temperature.
- It is **NOT** possible to go from Grilling or Searing (350-700°F) to Smoking temperatures (200-250°F). Grill must be shut down, charcoal extinguished, and restarted 1-2 hours later.
- **DO NOT** set temperature to higher than desired temperature in an attempt to reach desired temperature faster. This will result in over activating the charcoal and inability to maintain the desired temperature.
- **DO NOT** use the Heat Deflector at temperatures higher than 450°F.



## Care & Maintenance

In order to keep your grill in the best shape, it's important to keep it clean and maintained. Continued cleaning and care are key to ensuring a long life for your Char-Griller® grill. Have questions? Call, email or chat online with Char-Griller® Customer Service!

**IMPORTANT:** Prior to use, regularly wipe down the main heat sensor. If the heat sensor gets overly dirty it can impact performance.

### FINISH UP



- When you are finished grilling, clean your grates with the Char-Griller® Grate Scrape, Bristle Free Brush, or 3-in-1 Grill Brush and then lightly coat your grates with flaxseed or other food grade oil.
- Next close the lid, damper and fan cover allowing the fire to suffocate. (See page C-8)
- Wait until coals and ash have completely cooled before attempting to clean up or remove.

### CLEAN UP



- Wait until the fire is completely extinguished and the grill is cool to the touch before emptying the ashes.
- Brush out the fire bowl and give the charcoal grate a firm tap to loosen any ash that may be stuck.
- Unlatch the ash pan on both sides of the grill, push it up and bring it towards you to remove.
- Dump the ashes in a metal container and cover with water to ensure there are no lit coals, then you can dispose of the ashes.

### COVER UP



- Extend the life of your grill by using a Char-Griller® custom fit grill cover to protect it from the elements.
- Weather resistant polyester material protects against birds, dust, wind, rain and snow.

**\*\* ONLY EMPTY ASHES WHILE GRILL IS NOT IN USE AND COOL TO TOUCH \*\***

**IMPORTANT:** Charcoal is porous and holds moisture. DO NOT leave charcoal in your grill while you are not using it. Charcoal and ashes left inside the ash pan may reduce the life of your grill.



# Troubleshooting

QUESTION	ANSWER
<b>WHY IS MY GRILL NOT TURNING ON?</b>	<ul style="list-style-type: none"> <li>• Press the power button on the controller to verify, if controller will not turn on see next answer.</li> <li>• Verify controller is plugged into an outlet and that the power cord is securely plugged into the digital controller wiring harness.</li> <li>• Verify power at the electrical outlet. If the power cord is connected to a GFCI (ground fault circuit interrupter), check and reset if necessary.</li> <li>• If power is working at the outlet, contact Char-Griller® Customer Service for assistance at <a href="mailto:AutoKamado@CharGriller.com">AutoKamado@CharGriller.com</a>.</li> </ul>
<b>WHY IS THE FAN NOT RUNNING?</b>	<ul style="list-style-type: none"> <li>• The Grill temperature has reached its temperature goal.</li> <li>• The fan has been disconnected from the controller.</li> <li>• The fan has been disconnected from wiring harness.</li> </ul>
<b>WHY IS THE CONTROLLER TEMPERATURE NOT READING CORRECTLY?</b>	<ul style="list-style-type: none"> <li>• Check if the main Heat Sensor inside the grill is dirty, clean if necessary.</li> <li>• Check that the main Heat Sensor is fully plugged in.</li> <li>• Digital controller has a built-in algorithm that will approximate the grill temperature at the center of the grill grates not at heat sensor. (This may vary due to various conditions such as using the Heat Deflector, Fuel type, Weather conditions, etc.)</li> </ul>
<b>WHY IS THE TEMPERATURE OF MY GRILL FLUCTUATING?</b>	<ul style="list-style-type: none"> <li>• Temperature fluctuations are normal. Any significant fluctuation could be the result of wind, air temperature, improper use, or lack of grill maintenance.</li> <li>• If temperature overshoots the desired setting, pause the controller and open the grill lid to allow temperatures to decrease.</li> </ul>
<b>WHY IS MY GRILL SLOW TO HEAT UP?</b>	<ul style="list-style-type: none"> <li>• Check if the main heat sensor is dirty.</li> <li>• Allow 20-30 minutes for temperatures to equalize.</li> <li>• Weather conditions are humid or wet.</li> <li>• Charcoal has been used before.</li> <li>• Check if Grill Lid is open.</li> <li>• Check if Fan is running. If Fan is not running see “Why is the fan not running?”</li> </ul>
<b>WHY IS THERE EXCESSIVE SMOKE LEAKING FROM THE LID?</b>	<ul style="list-style-type: none"> <li>• Check if the Lid is fully closed and the latch is locked.</li> <li>• Check the Lid gasket for any damage.</li> </ul>
<b>WHY IS THE APP IS CONSTANTLY SHOWING “CONNECTION LOST!” OR “OFFLINE”?</b>	<ul style="list-style-type: none"> <li>• Wi-Fi signal could be weak. Try moving the grill closer to the router or the router closer to the grill, extending your wireless network, or connect to Bluetooth®.</li> <li>• Angle the Antenna on the back of the controller to point at the ground.</li> <li>• Try turning your Grill controller off and on.</li> <li>• Try re-pairing your grill with your WiFi Network or Bluetooth® device.</li> </ul>



# Troubleshooting (Continued)

CODE	ERROR MESSAGE
ErP	<ul style="list-style-type: none"> <li>• Check the Connection of the main Heat Sensor. Unplug the Connection, check the pins to make sure no pins are bend, and then reconnect.</li> <li>• Clean the Sensor with a cloth if excessively dirty.</li> <li>• If error code persists, you may need to replace your Heat Sensor. Contact Char-Griller® Customer Service for assistance at AutoKamado@CharGriller.com.</li> </ul>
ErH	<ul style="list-style-type: none"> <li>• Main heat sensor may be dirty.</li> <li>• Grill Temperature has exceeded 750°F.</li> <li>• Unplug Grill and Open the lid to cool down.</li> <li>• Check for Cause of the overheat: Fan malfunction or grease fire.</li> <li>• Plug Grill in to clear message.</li> </ul>
ErF	<ul style="list-style-type: none"> <li>• Check the connection of the fan. Unplug the fan connector and the power connector.</li> <li>• Check the fan and wiring for any damage . If the fan is damaged contact Customer Service at AutoKamado@CharGriller.com. You may need to replace your Fan.</li> <li>• If fan is not damaged, plug the connection back in and the power connector. Power on the grill to reset the Error code. If the Error code returns, contact Customer Service at AutoKamado@CharGriller.com. You may need to replace your Controller.</li> </ul>
ErU	<ul style="list-style-type: none"> <li>• Incorrect Voltage detected if using the wrong power adapter. Check if using the supplied power adapter or for malfunction of power adapter.</li> <li>• If error code persists, you may need to replace your Power Supply. Contact Char-Griller® Customer Service for assistance at AutoKamado@CharGriller.com.</li> </ul>



## ATTENTION!

Please Review ALL of the Lighting Instructions Prior to Operating Grill



- **DO NOT** use a charcoal chimney to ignite charcoal. Over-activation of charcoal will prevent controller from being able to control temperature.
- **BE PATIENT.** Time to reach desired temperature will vary by fuel type, number of fire starters and placement, as well as weather conditions. See Lighting Instructions on pages C-2 – C-5.
- Use **ONE** fire starter for smoking (200-250°F).
- **TWO** fire starters can be used to achieve higher temperatures (350-700°F).
- The appropriate fuel amount must be added to reach desired temperature. See Lighting Instructions on pages C-2 – C-5.
- When smoking (200-250°F), if the grill exceeds the set temperature by +50°F it may be challenging to reach desired temperature.
- It is **NOT** possible to go from Grilling or Searing (350-700°F) to Smoking temperatures (200-250°F). Grill must be shut down, charcoal extinguished, and restarted 1-2 hours later.
- **DO NOT** set temperature to higher than desired temperature in an attempt to reach desired temperature faster. This will result in over activating the charcoal and inability to maintain the desired temperature.
- **DO NOT** use the Heat Deflector at temperatures higher than 450°F.

## **General Grilling Tips & Warnings**

- When cooking with oil or grease, have a type BC or ABC fire extinguisher readily available.
- In the event of an oil or grease fire do not attempt to extinguish with water. Immediately call the fire department. A type BC or ABC fire extinguisher may, in some circumstances, contain the fire.
- The grill is HOT while in use and will remain HOT for a period of time afterwards and during cooling process. Use CAUTION. Wear protective gloves/mitts.
- Lid, lid latch, ash pan and latches are HOT while the grill is in use and during cooling. Wear protective gloves when working with and around these components.
- Grill has an open flame. Keep hands, hair, and face away from flame. Do NOT lean over grill when lighting. Loose hair and clothing may catch fire.
- Do not cover cooking grates with metal foil. This will trap heat and may cause damage to the grill.
- Never overfill fire bowl. This can cause serious injury as well as damage to the grill.
- When using electrical appliances, basic safety precautions should always be followed including the following: 1) Do not plug in the appliance until fully assembled and ready for use. 2) Use only approved grounded electrical outlet. 3) Do not use during an electrical storm. 4) Do not expose appliance to rain or water at any time.
- To protect against electrical shock do not immerse cord, plug or control panel in water or other liquid.
- Do not operate any appliance with a damaged cord or plug, or after appliance malfunctions or has been damaged in any manner. Contact Char-Griller® Customer Service for assistance at [AutoKamado@CharGriller.com](mailto:AutoKamado@CharGriller.com).
- Extension cords may be used if care is exercised in their use. If an extension cord is used: 1) The marked electrical rating of the extension cord should be at least as great as the electrical rating of the appliance; and 2) the cord should be arranged so that it will not drape over the counter top or tabletop where it can be pulled by children or tripped over unintentionally.
- The extension cord must be a grounding-type 3-wire cord.
- Outdoor extension cords must be used with outdoor use products and are marked with suffix “W” and with the statement “Suitable for Use with Outdoor Appliances.”
- CAUTION - To reduce the risk of electric shock, keep extension cord connection dry and off the ground.
- Do not let cord hang on or touch hot surfaces.
- Do not place cord on or near a gas or electric burner or in a heated oven.
- To disconnect, turn controller “OFF” then remove plug from outlet.
- Unplug from outlet when not in use and before cleaning. Allow appliance to cool completely before adding/removing internal components.
- Do not clean this product with a water sprayer or the like.
- If it is necessary to refill charcoal during use follow the specific reload instructions for this grill and always wear protective gloves.
- Never operate the grill with the temperature probe removed. This can cause the grill to overheat and cause serious personal injury and/or damage to the grill.
- Close Top Damper and Fan Cover after every use.
- Open Top Damper fully and open Fan Cover before every use.



# Cooking Guidelines

## HEAT KEY

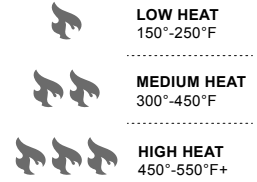

## USDA SAFE MINIMAL INTERNAL TEMPS







FISH & SHELLFISH:  
**145°F**





BEEF OR PORK STEAKS  
OR CHOPS: **145°F**





GROUND BEEF OR PORK:  
**160°F**

CHICKEN:  
**165°F**





*Cook times outlined in this chart are general guidelines that may vary depending on desired doneness, thickness, amount of each item being cooked, grill or grilling style, ambient temperature and/or weather. Char-Griller® recommends always using a cooking thermometer to gauge the internal temperature of all meat products.*

 <b>BEEF</b>	HEAT LEVEL	AVG. COOKING TIME
<b>SKIRT STEAK, MEDIUM</b> 1-INCH THICK		4-6 MIN.
<b>HOT DOG</b> 4 OUNCES		5-7 MIN.
<b>STEAK, MEDIUM</b> 1-INCH THICK - FILET MIGNON, RIBEYE, NEW YORK STRIP & PORTERHOUSE		6-8 MIN.
<b>BURGER</b> 3/4 - INCH THICK		8-10 MIN.
<b>HANGER STEAK, MEDIUM</b> 1-INCH THICK		8-10 MIN.

 <b>PORK</b>	HEAT LEVEL	AVG. COOKING TIME
<b>PORK CHOP, MEDIUM</b> 1-INCH THICK		8-10 MIN.
<b>SAUSAGE</b> 3-OUNCE LINK		10-13 MIN.
<b>PORK TENDERLOIN</b> 1 POUND		15-20 MIN.
<b>PORK SHOULDER/BUTT</b> 8 POUNDS		12 HOURS <small>APPROX. 90 MIN / LB.</small>

 <b>CHICKEN</b>	HEAT LEVEL	AVG. COOKING TIME
<b>CHICKEN BREAST OR THIGH</b> 4 OUNCES - BONELESS, SKINLESS		8-12 MIN.
<b>CHICKEN THIGH OR LEG</b> 3-6 OUNCES - BONE-IN*		35-45 MIN.
<b>CHICKEN BREAST</b> 10-12 OUNCES - BONE-IN*		35-45 MIN.
<b>WHOLE CHICKEN*</b> 8 POUNDS		3-5 HOURS

\*BONE-IN CHICKEN SHOULD INITIALLY BE COOKED OR "BROWNE" OVER DIRECT HEAT FOR SEVERAL MINUTES BEFORE BEING TRANSFERRED TO INDIRECT HEAT.

 <b>SEAFOOD</b>	HEAT LEVEL	AVG. COOKING TIME
<b>SHRIMP</b> LARGE		4-6 MIN.
<b>SCALLOP</b> 1 1/2 OUNCES		4-6 MIN.
<b>FISH, FILET</b> 1-INCH THICK		5-10 MIN.
<b>FISH, WHOLE</b> 1 POUND		15-20 MIN.



**FIND MORE  
RECIPES AT  
CHARGRILLER.COM**

# GRILLING RECIPES

- Cooking with a MEAT THERMOMETER ensures food is fully cooked. Insert thermometer into the thickest part of the meat, not touching bone, and allow 1 to 1 1/2 minutes to register temperature.
- USDA Safe Minimal Temperature is 165°F for chicken / poultry.
- USDA Safe Minimal Temperature is 145°F for Beef, Pork, Veal & Lamb (Steaks, chops, roasts).

## Direct Heat Recipes

### GRILLED FLANK STEAK WITH VEGETABLES

A vastly under-appreciated meat, the flank steak can be a flavorful and fast meal for the weeknights. Get dinner on the table in under 20 minutes and use a charcoal grill to get all the best flavors of summer with this flank steak recipe.

#### Ingredients:

- 1.5 Pound Flank Steak
- 1.5 tsp of Smoked Paprika
- 2 Garlic Cloves, Minced
- Salt and Pepper to Taste
- 4 Ears of Corn
- 2 Large Zucchini, Cut in Half Lengthwise
- 1 Pint Cherry Tomatoes
- 3 Tbsp of Olive Oil
- 1.5 Tbsp of Fresh Rosemary, Chopped
- 1 Tbsp of Red Wine Vinegar
- 2 Garlic Cloves, Minced (Oil Dressing)
- 2 Tbsp of Canola Oil

#### Instructions:

1. Season flank steak with paprika and garlic. Rub on all sides and season with salt and pepper. Brush with canola oil.
2. Brush corn, zucchini, and tomatoes with canola oil and season with salt and pepper.
3. Preheat the grill to medium high heat.
4. Add flank steak to grill, flip once and cook to desired internal temperature. About 4 to 6 minutes per side, let rest 5 minutes.
5. Add vegetables to grill and turn occasionally until lightly charred all over.
6. Whisk olive oil, rosemary, red wine vinegar, garlic and salt and pepper to taste in a small bowl.
7. Brush steak and drizzle vegetables with olive oil mixture and serve with steak immediately.

### PERFECT RIBEYE STEAKS

These Perfect Ribeye Steaks on the AKORN® Auto-Kamado™ are the best way to enjoy steaks at home. We love this recipe because this Ribeye Steak is so tender and juicy it will leave mouths watering.

#### Ingredients:

- Ribeye Steaks From Butcher Or Local Market
- 5-6 Medium Potatoes
- Couple Handfuls Of Green Beans
- Butter
- Olive Oil
- Salt/Pepper to Taste

#### Instructions:

1. Set AKORN® Auto-Kamado™ to 400°F
2. Take Steaks out of fridge, pat down with paper towels, drizzle and wipe down with small amount of olive oil and season with your favorite spices Salt and Pepper are fine here. I like to leave the steaks out of fridge at this point on the counter, but you may put back in fridge if you like.
3. Slice/chop up potatoes into 1" cubes, place in aluminum foil packet with butter and your favorite spices (again, salt/pepper will taste great!)
4. Place green beans in aluminum foil packet with butter and favorite spices
5. Once grill is up to temp, place potatoes and green beans directly on the grates.
6. After 20 minutes, flip potatoes and green beans
7. 15-20 minutes later remove potatoes and green beans
8. Set grill temp to 450-500 F
9. Place steaks directly on grill and let cook for 2 minutes
10. Twist steaks 90 degrees and let sit for 2 minutes (creates the crosshatch)
11. Flip steaks and let cook for 2 minutes
12. Twist steaks and let cook for 2 minutes
13. You should now be at rare / medium rare - continue to cook until you reach the desired temperature your family likes.



## QUICK AND EASY GRILLED PORK TENDERLOIN

Need dinner in a hurry? This quick and easy pork tenderloin recipe is a crowd pleaser. Pair with grilled red potatoes and asparagus for a simple but flavorful dinner!

### Ingredients:

2 Pork Tenderloins  
2 tsp Paprika  
1 tsp Garlic Powder  
1 tsp Cilantro  
1 tsp Oregano  
Salt and Pepper to Taste  
Olive Oil

### Instructions:

1. Blend spices together in a bowl. Rub pork with olive oil and then season liberally on both sides with spice blend.
2. Set up your Char-Griller for direct cooking. Ignite burners and turn to medium high.
3. Place pork on the grill and cook for 8 to 10 minutes per side or until the internal temperature reads 165°F or until desired internal temperature (USDA Safe Minimal Temperature for Pork is 145°F).
4. Remove from the grill and let rest for 10 minutes.

## HAMBURGERS

Season to taste with Char-Griller® "Original" All-Purpose or Steak Seasoning.

You may also marinate by allowing to stand in marinade for 1 or 2 hours at room temperature before cooking, or let stand in covered dish in refrigerator up to 24 hours.

### Instructions:

1. Bring to room temperature before cooking.
2. Mix in chopped onions, green peppers, salt, sear 3/4 inch patties on each side.
3. Cook over medium heat with lid down to avoid flare-ups.
4. Cook each side 3 to 7 minutes according to desired temperature.
5. Ground meat will be done when juices run clear (USDA Safe Minimal Temperature for ground meat is 160F).
6. Burgers can be basted with marinade when turning and/or other ingredients can be mixed in with the ground beef such as chili sauce or powder.

## JUICY LUCY HAMBURGERS

If you think there is no way that the classic hamburger could get better, just wait until you try the Char-Griller® Juicy Lucy Burger. Packed with flavor and melted cheese, these burgers are sure to be a hit this summer.

### Ingredients:

1.5 lbs Ground Beef  
1/2 Packet of Dry French Onion Soup Mix  
1/4 Cup of French Dressing  
2 Tbsp of Worcestershire  
1/2 tsp of Salt  
1/4 tsp of Black Pepper  
Block of Cheddar Cheese

### Instructions:

1. Slice cheese into blocks approximately 1/4 inch thick and 2 inches wide by 2 inches tall.
2. Add French Onion Soup Mix, Salt, Pepper, French Dressing, and Worcestershire sauce to ground beef and mix well.
3. Take a portion of the meat and form into a patty.
4. Put the cheese block in the middle of the patty and wrap the cheese completely with the beef. Form a patty with the cheese inside.
5. Repeat with the remaining beef and cheese.
6. Preheat the grill to 400°F
7. Cook burgers for 3 minutes on the first side and then flip.
8. Cook the burgers for 6 minutes on the other side. Ground meat will be done when juices run clear (USDA Safe Minimal Temperature for ground meat is 160F).
9. Add desired toppings and enjoy!

## SHRIMP (Peeled) & CRAYFISH

### Instructions:

1. Place on skewers.
2. Coat with melted butter and garlic salt.
3. Grill 4 minutes on each side or until pink. Cocktail sauce optional.

## HOT DOGS

### Instructions:

1. Grill with lid open for approximately 6 minutes.
2. Turn every few minutes.

## **JALAPEÑO BACON BLANKET POPPERS**

Need an easy to make snack for this big game? These Jalapeno Bacon Blanket Poppers are a crowd pleaser and are super easy to whip up on the grill. The bacon gets crispy quickly and doesn't burn easily since it's just sitting on top of the cream cheese filling. Easy, delicious and the perfect size for an appetizer, your friends and family will be asking you to make these again and again!

### **Ingredients:**

4 Jalapeños  
Char-Griller Steak Rub to Taste  
1/3 Cup Cream Cheese  
3 Slices of Bacon  
Shredded Cheese to Taste

### **Instructions:**

1. Mix cream cheese, shredded cheese, Char-Griller® Steak Rub in a bowl and set aside.
2. Slice jalapeños through the middle to make it boat shaped.
3. Using a spoon remove the pith and seeds to create room for the filling.  
*Tip: If you like heat then leave some seeds behind. Seeds provide the heat.*
4. Fill jalapeños with filling.
5. Slice bacon into small strips then lay it over the filling on the jalapeños.
6. Sprinkle a small portion of the Char-Griller® Steak Rub on top of the bacon.
7. Fire up your Char-Griller Grill to 400°.
8. Place Jalapeño Bacon Blanket Poppers in the grill/smoker and smoke for 30 minutes or when the bacon is golden brown. Remove and enjoy!

## **Indirect Heat Recipes**

### **HASSLEBACK POTATOES**

A side dish that can basically be a meal in and of itself, these Hassleback Potatoes can be completely customized with toppings and types of cheese!

### **Ingredients:**

6 Russet Potatoes  
1 Pack of Cheddar Cheese Slices  
1 Pack of Pepper Jack Slices  
Chipotle Powder  
Oregano  
Salt and Pepper to Taste  
Cooked Bacon (Diced)  
Chives (Sliced)  
Sour Cream

### **Instructions:**

1. Set up your grill for indirect cooking.
2. Cut thin slices in the width of the potatoes, but be careful to not slice all the way through.
3. Wrap the potatoes in foil and place on the side of the grill away from the flames. Allow to cook until tender. About 45 minutes to an hour.
4. Remove potatoes from the grill and unwrap.
5. Place alternating slices of cheddar and pepperjack in the potato.
6. Season potatoes with chipotle powder, salt, pepper, and oregano.
7. Place potatoes back on the grill unwrapped for 10 to 12 minutes or until cheese is melted.
8. Garnish with bacon, chives, sour cream and serve.

### **SWEET CORN IN HUSKS**

### **Instructions:**

1. Trim excess silk from end and soak in cold salted water 1 hour before grilling.
2. Grill 25 minutes – turning several times.



## GARLIC PARMESAN CHICKEN WINGS

Replicate the signature flavors of your favorite wing spot with this marinated Garlic Parmesan Recipe.

### Ingredients:

4 lbs. of Chicken Wings  
16 oz. Bottle Italian dressing  
1 Cup of Shredded Parmesan Cheese  
1/2 Tbsp. Onion Salt  
1/2 Tbsp. Black Pepper  
1 Cup of Butter  
1 Tbsp. Oregano  
2 Tbsp. Garlic Powder  
A pinch of rosemary

### Instructions:

1. Marinate wings overnight or at least four hours in Italian dressing
2. Add charcoal to one side of grill for indirect grilling, or use Heat Deflector and add flavored wood chips/chunks if desired
3. Let grill preheat to 275°F
4. Place wings on indirect heat side of grill
5. Smoke wings for 45-60 minutes, until internal temp reaches 170°F
6. While wings are smoking, make garlic Parmesan sauce by mixing Parmesan cheese, garlic powder, onion salt, black pepper, butter, oregano and rosemary
7. Remove wings from grill and toss in garlic Parmesan sauce

## CEDAR PLANK SALMON

Think you can't get the perfect smoked salmon on a gas grill? Think again. With indirect grilling, you can get the perfect cedar plank soaked salmon every time.

### Ingredients:

2 Cedar Planks  
2 Salmon Filets  
Olive Oil  
Rosemary  
Salt and Pepper to Taste

### Instructions:

1. Soak cedar planks in water for at least 8 hours.
2. Set up your grill for Indirect cooking
3. Add 30 to 40 charcoal briquettes to one side of the grill
4. Ignite charcoal with gas burners set to medium high

5. Once charcoal is lit, turn off gas burners and allow to fully ash over
6. Rub salmon on both sides with olive oil.
7. Season with salt and pepper, rosemary sprigs and slices of lemon
8. Place salmon on the side of the grill away from the charcoal
9. Cook salmon for 15 minutes or until flakey.

## CHILI-LIME CHICKEN THIGHS

Perfect for tacos, fajitas, nachos, or as a dish all on it's own, this Chili-Lime Chicken Thighs Recipe, prepared by our ambassador, BBQFiends, can be quickly cooked on a grill for a weeknight meal or cooked with charcoal on the weekend to add just the right kick of smokey flavor.

### Ingredients:

3 Lbs Chicken Thighs  
2 Tbsp Favorite BBQ Chili Seasoning  
1 Lime  
Chopped Cilantro for Garnish  
1 Lime Juiced (Marinade)  
1 - 12 oz Beer (Marinade)  
Salt & Pepper to Taste (Marinade)

### Instructions:

1. Trim excess fat off chicken thighs and place in a large bowl. Add the marinade ingredients and let sit in the refrigerator for 1-2 hours before cooking.
2. Remove chicken from marinade and season with your favorite BBQ chili seasoning. Get the grill up to 375° F and place the chicken over indirect heat.  
*\*Tip: To get crispier chicken skin flip the chicken over about half-way through the cook and move to direct heat. Make sure internal temp is at least 165F before removing for the grill.\**
3. Pull the chicken and garnish with chopped cilantro and a squeeze of lime over the top.
4. Serve and enjoy!



# **Smoking Recipes**

## **“CERTIFIED” PORK BUTT**

A great pork butt recipe perfect for beginners and pitmasters alike. This slow smoked pork butt recipe is great shredded and piled high with coleslaw for a sandwich or eaten on it's own straight out of the pan!

### **Ingredients:**

2 Pork Butts (6-10 lbs. each)  
Apple juice  
Your favorite rub/seasoning  
Mustard

### **Preparing the Meat:**

1. Remove the pork butt from the plastic wrap & pat dry using a paper towel.  
*Tip: Choose a pork butt with a full fat cap. This helps the meat while it's smoking for a long period of time.*
2. Trim the excess fat that is loose and pulls up easily. Score the fat cap 1/8 to 1/4-inch-deep diagonally, spaced out 1/2 to 1 inch apart.  
*Tip: Scoring the meat allows the seasoning and smoke to penetrate into the pork butt.*
3. Fill the marinade injector with apple juice and inject into the top and sides of the meat.
4. Spread a coating of mustard using a basting brush all over the pork butt.
5. *Tip: This allows the rub to stick to the pork butt.*
6. Generously season the pork butt on all sides with your favorite rub.  
*Tip: After seasoning, wrap in Saran Wrap and store in the refrigerator overnight or 8-10 hours. This allows the rubs to penetrate and apple juice to tenderize the pork butt.*

### **Cooking Directions:**

1. Ignite charcoal and preheat the smoker to 225°F.
2. Add boiling water to the drip pan and place under the grill grate.  
*Tip: This will add moisture for the cook and collect the drippings .*
3. Smoke the pork butts for 2 hours per pound at 225°F, until the meat reaches an internal temperature of 160°F.  
*Tip: Maintain a 225°F temperature, check fire hourly or when needed. Also spritz with apple juice every time you add fuel to your fire. Spritzing adds moisture and flavor. It prevents the pork butt from drying out and helps to create the bark. Monitor the temperature using a folding probe thermometer and/or remote thermometer.*

4. Remove the pork butts from the smoker and double wrap in foil. Before closing the wrap, add 1 Cup of apple juice and 1 stick of butter for each pork butt, more seasoning and BBQ sauce, to taste.
5. Place back in the smoker and cook until the pork butt reaches an internal temperature of 199°F, then remove from the smoker.  
*Tip: Wrap pork butt in a large towel and place in a cooler or just set to the side for a minimum of 1-2 hours for resting. This allows the meat to cook down and stop cooking and is a major key in the process.*
6. After resting, remove the towel and foil. Pull apart the pork using two forks or meat claws.
7. Make pulled pork sandwiches and endless pulled pork dishes. Enjoy!

## **BRISKET**

The brisket recipe is a traditional take on the smoked classic, promising tender, smoky results.

### **Ingredients:**

10 ½ lb. beef brisket  
½ Cup paprika  
¼ Cup packed light brown sugar  
3 Tbsp. salt  
3 Tbsp. coarse black pepper  
3 Tbsp. Chili powder  
Apple juice  
Water

### **Instructions:**

1. Using a sharp knife, trim the fat from the brisket leaving an even, thin layer on the top.
2. In a medium bowl, combine paprika, light brown sugar, Chili powder, salt and pepper and mix well to make rub seasoning. Using your hands, or a shaker, generously apply rub all over.
3. Wrap the brisket in plastic wrap and refrigerate for at least 12 hours.
4. When setting up the grill, add wood chips/chunks to charcoal and add Heat Deflector with an aluminum pan on top. Pour apple juice and water into the pan, about halfway full. Place a temperature probe at grate level and heat grill to 220°F.
5. Place brisket on grates, fat side up, and allow to smoke for 5 hours. After 5 hours, wrap the brisket in butcher paper and return to grill at 220°F. Brisket is done when the internal temperature reaches 195°F. Allow the brisket to rest for 1 hour.
6. Slice, serve and enjoy!



## 3-2-1 RIBS

The 3-2-1 rib method might be something you have seen thrown around on social media. It's a popular technique for smoking ribs that are tender, juicy, and come clean off the bone. Simple and easy to follow, this is a surefire way to guarantee your ribs are finger lickin' good.

The 3-2-1 Method is a process that involves smoking the ribs for three hours, wrapping them in foil and braising for two hours, and the smoking unwrapped for one hour. This not only helps the ribs cook faster, it ensures an even smoke ring, and more tender meat.

### Ingredients:

4 Racks of Ribs  
2 Cups of Apple Cider, 2 Additional Cups in Spray Bottle  
8 Tbsp of Salted Butter  
1 Cup of Favorite BBQ Sauce  
1 Cup Dark Brown Sugar  
Char-Griller Rib Rub  
4 Tbsp Honey

### Instructions:

1. Prepare your Char-Griller® Offset Smoker for smoking by starting half a chimney starter of charcoal and adding it to the Side Fire Box. Alternatively, prepare your grill for the indirect method with coals arranged opposite where you plan to place the ribs.  
*Tip: Add about half a chimney of unlit charcoal to the Side Fire Box close to the barrel before adding the lit charcoal next to it. The lit charcoal will gradually light the unlit charcoal to help maintain temperature for longer.*
2. Add three to four chunks of Apple Wood and close the lid.
3. Allow the grill to heat up to about 200°F.
4. Remove the membrane from the ribs.  
*Tip: Start at the narrower end of the rack, carefully work a paring knife under the membrane to get it started, and remove the membrane using a paper towel.*
5. Liberally season both sides of the ribs with Char-Griller® Rib Rub.
6. Open the grill and raise the adjustable fire grate to the top level. This ensures even smoke distribution.
7. Place a drip pan(s) full of water under the grates and on top of the fire grate in the main barrel.
8. Place ribs bone side down on the grates, close the lid and allow to smoke for three hours.  
*Tip: Place the exposed bone side of the rib rack towards the Side Fire Box to get the meat to pull away from the bone better. If using the indirect method, place ribs opposite the coals.*
9. Periodically check the temperature to ensure it is holding steady at 200°F. If you have to add charcoal, only add lit charcoal.
10. Every 30 minutes, spray the ribs with Apple Cider and move the rib rack that is closest to the Side Fire Box to the side of the grill that is furthest from the Side Fire Box and move the other rib racks closer to the Side Fire Box to accommodate. Repeat the spray and rotate method every 30 minutes.
11. Remove ribs from the grill after three hours.
12. Tear off a large sheet of heavy-duty aluminum foil. (One for each rack of ribs.)
13. Place one rack of ribs bone side up on each piece of aluminum foil.
14. Coat the bone side of ribs with brown sugar, honey, and four pats of butter.
15. Pour over ½ cup of apple cider.
16. Fully crimp the edges of the foil together to cover the ribs.
17. Fully crimp the edges of the foil together to cover the ribs.
18. Repeat with the other three racks of ribs.
19. Transfer ribs back to the smoker and increase the temperature to 225°F.
20. Do this by opening the dampers a little more and adding another half a chimney of lit charcoal if needed.
21. Allow ribs to braise for two hours.
22. Continue to rotate the ribs as outlined in step 8b to ensure that all of the racks get time close and far away from the fire.
23. Remove the ribs from the grill and foil. Place back on the grill bone side down.
24. Brush ribs with your favorite BBQ sauce and cook for one hour at 225°F.
25. Remove and enjoy!

## PORK BELLY BURNT ENDS

Really just a fancy name for Meat Candy, these Pork Belly Burnt Ends are a great way to try your hand at some smoking techniques. Consider making a double batch because it's all too easy for these the just vanish.

### Ingredients:

Slab of Pork Belly  
BBQ Rub  
1 Stick Butter  
1/2 Cup Brown Sugar  
Honey  
BBQ sauce  
8 oz Apple Juice

### Instructions:

1. Remove skin from the pork belly.
2. Cut up pork belly in 1.5" squares.
3. Set smoker to 250-275F - indirect - add cherry wood.
4. Place cubed pork belly pieces on smoker - cook for 1.5-2 hours
5. Place pork belly in aluminum pan - pour in brown sugar, honey, and pads of your butter.
6. Cover, and place in smoker for another 1.5-2hrs (until about 205F).
7. Grab a new pan.. drizzle with glaze(4 oz apple juice 1 cup of bbq sauce) and shake up so they're covered.
8. Return pieces to smoker, uncovered for approx 5-10 mins until tacky.

## CRISPY CHICKEN WINGS

My favorite recipe for football is smoked chicken wings with crispy skin. This is something that is often attempted but never perfected. I'm here to tell you today that perfection isn't out of reach when you're using the right tool, and for me, the Char-Griller AKORN® Auto-Kamado™ is the perfect tool for making smoked chicken wings with delicious crispy skin. These are quick to make and delicious, so give these a try at your next backyard tailgate and let me know what you think.

### Ingredients:

1 Pack of Whole Chicken Wings  
1 Tbsp of Kosher Salt  
1/4 Cup of your Favorite Wing Sauce or Glaze

### Instructions:

1. Set AKORN® Auto-Kamado™ to 400°F
2. Season the bottom side of the chicken wings evenly with the kosher salt, then place them on the AKORN® Auto-Kamado™ around where the edge of the heat deflector is below them.
3. After ten minutes, flip the wings over and inward to protect them from the direct heat. Also, give the grate ¼

- turn. Open the top vent up to the number 4.
4. After ten minutes, flip the wings back over and give the grate another ¼ turn.
5. After ten minutes, flip the wings back over and give a final ¼ turn.
6. After ten minutes, check the wings' internal temperatures; they should be around 200 degrees.
7. Place the wings in a bowl and pour the sauce or glaze over the top and toss until they are evenly covered.

## SMOKED CHICKEN PARTS AND HALVES

### Instructions:

1. Rinse pieces in cold water and pat dry with paper towels.
2. Brush each piece with Olive Oil and season to taste with salt and pepper.
3. Brown pieces directly above coals with lid open and grill on high or medium heat for several minutes.
4. Then place pieces on cooking grate in indirect cooking area.
5. With the grill on low heat, cook with lid down for 55 to 60 minutes or until done. Do not use Olive Oil or salt and pepper if using marinade

## SMOKED BAKED HAM:

You can smoke fully cooked canned ham or smoked and cured whole ham or shank or butt portion.

### Glaze

1 cup of Light Brown Sugar, firmly packed  
1/2 cup Orange Juice  
1/2 cup Honey

### Instructions:

1. Combine sugar, juice and honey. Let glaze sit for at least 4 hours.
2. Remove rind and score fat diagonally to give a diamond effect.
3. Insert a whole clove into the center of every diamond.
4. Place ham with fat side up in center of cooking grate. Close lid.
5. About 9 minutes per pound is suggested for fully cooked hams. Smoked or cured ham, which is not fully cooked, should be cooked to an internal temperature of 160°F.
6. Baste with ham glaze 3 or 4 times during last 30 minutes of cooking time.
7. Garnish with pineapple rings about 15 minutes before end of cooking time.



## SMOKED TURKEY

### Instructions:

1. Empty cavity rinse and pat dry with paper towel.
2. Tuck wing tips under the back and tie legs together.
3. Place in center of cooking grate directly above foil drip pan of water.
4. Smoke for 12 minutes per pound. Allow several extra minutes per pound if stuffed to allow for expansion.
5. Use a meat thermometer for best results (190°F internal).

## SMOKED VENISON WITH BACON

### Venison Marinade

- 1 cup Balsamic or Red Wine Vinegar
- 1 cup Olive Oil
- 2 oz. Worcestershire
- ½ oz. Tabasco
- 2 Tbsp. Seasoning Salt
- 1-2 Chopped Jalapeños
- 3 oz. Soy Sauce

### Bacon Marinade

- 2 oz. Red Wine Vinegar
- 2 oz. Worcestershire 4 dashes Tabasco

### Instructions:

1. Place leg of venison in a container and marinate for 2-4 days, turning daily.
2. Leave bacon to marinate overnight.
3. Remove leg from refrigerator at least an hour before cooking.
4. Season generously with seasoned salt and coarse ground black pepper.
5. Wrap 1 lb. bacon over the top of the leg, and smoke 20-25 minutes per pound, or until tender.
6. Do not overcook.



**FIND MORE  
RECIPES AT  
CHARGRILLER.COM**

## Marinades

### CHICKEN MARINADE

#### Ingredients:

- ½ Cup Soy Sauce
- ¼ Cup Olive Oil
- ¼ Cup Red Wine Vinegar
- 1 Tsp Oregano
- ½ Tsp Sweet Basil
- ½ Tsp Garlic Powder with Parsley
- ¼ Tsp Pepper

#### Instructions:

1. Pour over chicken pieces in non-metal dish
2. Cover and refrigerate overnight, turning occasionally. Use marinade to baste chicken while cooking.

### MEAT MARINADE: (For steaks, chops, and burgers)

#### Ingredients:

- ¼ Cup Soy Sauce
- 2 Large Onions
- 2 Garlic Cloves, crushed
- 2 Tsp Salt
- 2 Tsp Paprika
- 1 Tsp Fresh Ground Pepper

#### Instructions:

1. Combine ingredients in an electric blender, cover, and process at high speed 1 minute or until mixture is very smooth.
2. Allow meat to stand in marinade at room temperature for 2 hours or refrigerate up to 24 hours in a covered dish.
3. Bring meat to room temperature before cooking.

### SHISH KABOB MARINADE

#### Ingredients:

- 1 Cup Soy Sauce
- ½ Cup Brown Sugar
- ½ Cup White Vinegar
- ½ Cup Pineapple Juice
- 2 Tsp Salt
- ½ Tsp Garlic Powder

#### Instructions:

1. Mix all ingredients together.
2. Marinate beef in mixture a minimum of 4 hours.



# FAVORITE ACCESSORIES

FOR THE FULL LINE OF ACCESSORIES VISIT [CHARGRILLER.COM](http://CHARGRILLER.COM)



## Custom Fit Cover

Weather Resistant  
Protects Grill Finish

Model #6455



## 15" Pizza Stone

Withstands temperatures over 1200°F, transform your AKORN® Auto-Kamado™ into an outdoor pizza oven

Model #6202



## Grill Wok

Stainless Steel Construction,  
Non-stick surface, perfectly cook vegetables on the grill

Model #8610



## Grill Tool Kit

Classic Trio of  
Grilling Essentials  
Stay Cool™ Handles  
great for every grill master

Model #8651



## Folding Probe Thermometer

Stainless steel fast-read probe accurately measures temperature  
Easily switch from °F to °C  
Auto ON/OFF feature for extended battery life

Model #6304



## Original All-Purpose BBQ Rub

Pairs well with all types of meat and fish

Model #85501



**This Page Intentionally  
Left Blank**

**This Page Intentionally  
Left Blank**



**P.O. Box 30864**  
**Sea Island, GA 31561**  
**[www.CharGriller.com](http://www.CharGriller.com)**  
**[AutoKamado@CharGriller.com](mailto:AutoKamado@CharGriller.com)**

